

INSTRUCTION SHEET

Bulletin 511 Type "S" A-c Brake - 4"

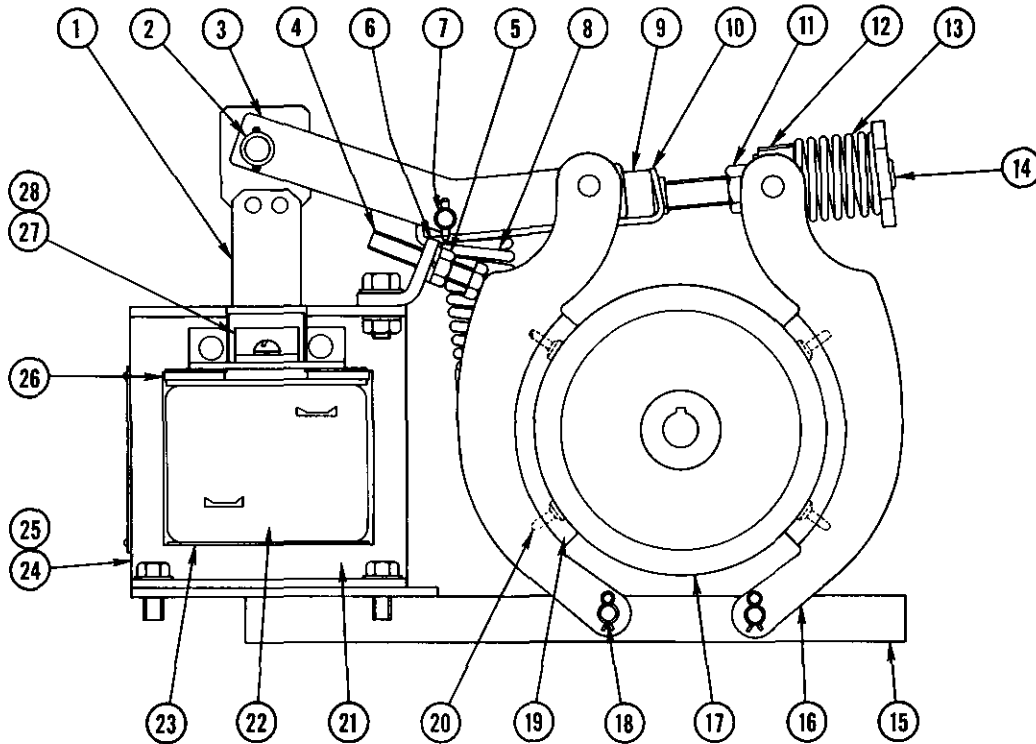

INSTRUCTIONS (See Figure 1)

1. Mounting — Clamp the brake on the wheel by compressing the torque spring "D" (See Fig. 1) by tightening the adjusting nut "E". Insert shims between the mounting stand and the base of the brake until the brake is setting solid on the base. Note — These brakes **should** be mounted in a **horizontal position** with the base below the solenoid and shoes. Side or vertical mounting can result in accelerated wear of the solenoid.

2. Adjustment — a. Compress the torque spring "D" until the desired torque is obtained. The approximate compressed length of this spring, to obtain rated torque, is given in the table below and on a small plate mounted on the pivot block, item 12. It is an approximate dimension and further adjustment may be necessary.

While making this adjustment maintain a clearance of $\frac{1}{64}$ " at "C" when the brake is applied. When the desired torque is obtained be sure the clearance "C" is $\frac{1}{64}$ ". The security lock nut "B" will hold itself in this position.

b. Equalize the clearance between the shoes and wheel when the brake is released by setting the screw "A".

3. Re-Adjustment — When the lining wears, the clearance "C" decreases. Never permit this clearance to become zero since complete loss of braking torque will result. When the clearance "C" becomes low, again adjust to $\frac{1}{64}$ " by turning screw "E". No change in torque will result from this adjustment if nut "B" is not changed.

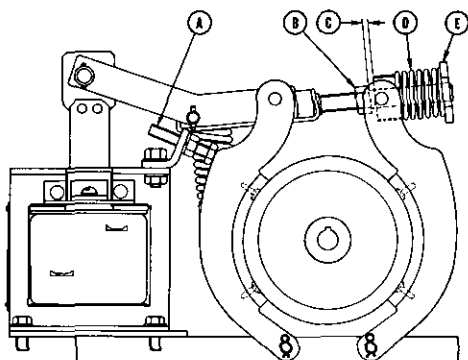

Size of Brake	Torque Rating	Compressed Length of Spring "D"
4"	3 Lbs. Ft.	1.350 In.
4"	10 Lbs. Ft.	1.225 In.
4"	15 Lbs. Ft.	1.100 In.

RENEWAL PARTS Information Required

Parts **CANNOT** be sent promptly unless you include the **FOLLOWING** with your order: **PUBLICATION NO. 19320, ITEM NO., PART NO., DESCRIPTION AND COMPLETE NAMEPLATE DATA ON THE BRAKE**

Item No.	Description of Part	No. Req.	Part No.
▲ 1	Plunger	1	51-97-4
2	Link pin assembly (includes link pin and neoprene tubes)	1	13-3864-2
	Link pin	1	13-3864-3
	Neoprene tube	2	56-2561-10
	Spring pin	2	13-3186
3	Lever	2	24-4424
4	Screw 1/4-20x1 1/2 long	1	911-5452Z
5	Nut 1/4-20	1	915-24Z
6	Bracket	1	79-672
7	Link pin	1	13-3863
	Spring pin	2	13-3186
▲ 8	Spring	1	69-4908
9	Adjusting stud nut	1	15-541
10	Spring gland	1	49-1978
11	Lock nut	1	15-292
	Washer	1	916-882Z
12	Pivot Block	1	17-473-2
▲ 13	Spring	1	69-202
14	Adjusting stud	1	14-272
15	Base	1	17-474
16	Brake Shoe Complete (includes items 19 and 20)	2	48-306
*17	Brake wheel (see below)	1
18	Pin	4	13-431
19	Brake Lining	2	48-80
20	Grove pin	8	13-4762
21	Solenoid frame	1	17-488
▲ 22	Coil (Give No. on Coil)	1
23	Coil washer	2	16-255
24	Cover	1	47-828
25	Case	1	39-507
26	Coil spring	2	69-276
▲ 27	Plunger guide	2	54-300
28	Solenoid without coil (includes items 1, 21, 23, 26, and 27)	1	88-3015-4
▲ 29	Renewal set of linings (includes items 19 and 20)	1	6-166

▲ We recommend that these items be stocked. The quantity to be stocked will depend, upon the total number in use.

*Give the catalog "H" No. when it is stamped on the wheel or, if this number does not appear on the wheel, give the complete brake nameplate data and the bore and the keyway dimensions.