

Enrange MLTX2 Transmitter (Intrinsically Safe)

Wireless Controls



MAGNETEK
MATERIAL HANDLING
ENRANGE

April 2014
Part Number: 198-80202-2001 R0
© 2014 Magnetek Material Handling

Your New Radio Remote

Thank you for your purchase of Magnetek's Enrange™ brand MLTX2 Radio Remote Equipment Control. Magnetek has set a whole new standard in radio-remote performance, dependability, and value with this unique new line of handheld transmitters.

If your product ever needs modification or service, please contact one of our representatives at the following locations:

U.S. Service Information

For questions regarding service or technical information contact:

+1.866.MAG.SERV

+1.866.624.7378

International Service

+1.262.783.3500

World Headquarters:

Magnetek, Inc.
N49 W13650 Campbell Drive
Menomonee Falls, WI 53051

Telephone: +1.800.288.8178

Website: www.magnetekmobilehydraulic.com

e-mail: mhcustomerservice@magnetek.com

Fax Numbers:

Main: +1.800.298.3503

Sales: +1.262.783.3510

Service: +1.262.783.3508

Canada Service Information:

4090B Sladeview Crescent
Mississauga, Ontario
L5L 5Y5 Canada
Phone: +1.800.792.7253
Fax: +1.905.828.5707
+1.416.424.7617 (24/7 Service pager)

EU Market Contact:

Brian Preston
Magnetek (UK) Ltd.
Unit 3 Bedford Business Centre
Mile Road
Bedford, MK42 9TW UK
Phone: +44.1234.349191
Fax: +44.1234.268955

©2014 MAGNETEK

All rights reserved. This notice applies to all copyrighted materials included with this product, including, but not limited to, this manual and software embodied within the product. This manual is intended for the sole use of the person(s) to whom it was provided, and any unauthorized distribution of the manual or dispersal of its contents is strictly forbidden. This manual may not be reproduced in whole or in part by any means whatsoever without the expressed written permission of MAGNETEK.

TABLE OF CONTENTS

1.0	INTRODUCTION	4
1.1	PRODUCT MANUAL SAFETY INFORMATION	4
1.2	WARNINGS AND CAUTIONS	5
2.0	CRITICAL INSTALLATION CONSIDERATIONS	6
2.1	GENERAL	6
2.2	PERSONS AUTHORIZED TO OPERATE RADIO CONTROLLED EQUIPMENT	7
2.3	SAFETY INFORMATION AND RECOMMENDED TRAINING FOR RADIO CONTROLLED EQUIPMENT OPERATORS	7
2.4	TRANSMITTER UNIT	8
2.5	PRE-OPERATION TEST	9
2.6	HANDLING BATTERIES	9
2.7	BATTERY DISPOSAL	9
2.8	SPECIFIC CONDITIONS OF SAFE USE	10
3.0	MLTX2 TRANSMITTER STANDARD CONFIGURATION AND OPERATION	11
3.1	INSTALLING BATTERY PACK	12
3.1.1	Approved Batteries for Intrinsically Safe Operation	12
3.1.2	Intrinsically Safe Alkaline Battery Pack	12
3.2	TURNING THE TRANSMITTER ON AND OFF	14
3.2.1	Turning On the Transmitter	14
3.2.2	Pulling In the Machine Stop Relay	14
3.2.3	Turning Off the Transmitter	14
3.3	MACHINE STOP SWITCH (For Emergency Stopping Only)	15
3.4	STATUS LED	15
3.5	NORMAL OPERATING MODE WITH STANDARD STATUS LED	15
3.5.1	Watch Dog Indicator (Steady Blinking Status LED)	15
3.5.2	Switch Change Indicator (Rapidly Blinking Status LED)	15
3.5.3	Low Battery Level Indicator (Blinking Red Status LED)	15
3.6	JOYSTICKS AND PADDLES/LEVERS	15
3.7	ROTARY SELECTOR SWITCH	15
3.8	AUXILIARY SWITCHES	16
3.9	CONNECTING THE MLTX2 TO A COMPUTER	16
4.0	TRANSMITTER SETUP	17
4.1	TRANSMITTER SETUP SETTINGS WITH STANDARD STATUS LED	17
5.0	TRANSMITTER RF CHANNEL CONFIGURATION SETTINGS	19
5.1	FCC/ATEX/IECEX STATEMENTS	19
5.2	CHANNEL AND FREQUENCY DESIGNATIONS BY COUNT	20
5.3	OPTIONAL FREQUENCIES AND CHANNELS	21
6.0	GENERAL TROUBLESHOOTING	22
6.1	ASSEMBLY AND REPLACEMENT PARTS	22
7.0	TECHNICAL SPECIFICATIONS	23

1.0 INTRODUCTION

Thank you for your purchase of Magnetek's Enrange™ brand MLTX2 Radio Remote Equipment Control.

These instructions are to be used as a reference for personnel operating the Enrange brand MLTX2 Radio Remote Equipment Control and the equipment that this Enrange brand MLTX2 Radio Remote Equipment Control is attached to.

The user of these instructions should have basic knowledge in the handling of electronic equipment.

1.1 PRODUCT MANUAL SAFETY INFORMATION

Magnetek, Inc. (Magnetek) offers a broad range of radio remote control products, control products and adjustable frequency drives, and industrial braking systems for overhead material handling applications. This manual has been prepared by Magnetek to provide information and recommendations for the installation, use, operation and service of Magnetek's material handling products and systems (Magnetek Products). Anyone who uses, operates, maintains, services, installs or owns Magnetek Products should know, understand and follow the instructions and safety recommendations in this manual for Magnetek Products.

The recommendations in this manual do not take precedence over any of the following requirements relating to cranes, hoists and lifting devices:

- Instructions, manuals, and safety warnings of the manufacturers of the equipment where the radio system is used,
- Plant safety rules and procedures of the employers and the owners of facilities where the Magnetek Products are being used,
- Regulations issued by the Occupational Health and Safety Administration (OSHA),
- Applicable local, state or federal codes, ordinances, standards and requirements, or
- Safety standards and practices for the overhead material handling industry.

This manual does not include or address the specific instructions and safety warnings of these manufacturers or any of the other requirements listed above. It is the responsibility of the owners, users and operators of the Magnetek Products to know, understand and follow all of these requirements. It is the responsibility of the owner of the Magnetek Products to make its employees aware of all of the above listed requirements and to make certain that all operators are properly trained. **No one should use Magnetek Products prior to becoming familiar with and being trained in these requirements.**

WARRANTY INFORMATION

FOR INFORMATION ON MAGNETEK'S PRODUCT WARRANTIES BY PRODUCT TYPE, PLEASE VISIT WWW.MAGNETEKMOBILEHYDRAULIC.COM.

1.2 WARNINGS AND CAUTIONS

Throughout this document WARNING and CAUTION statements have been deliberately placed to highlight items critical to the protection of personnel and equipment.

WARNING – A warning highlights an essential operating or maintenance procedure, practice, etc. which, if not strictly observed, could result in injury or death of personnel, or long term physical hazards. Warnings are highlighted as shown below:



CAUTION – A caution highlights an essential operating or maintenance procedure, practice, etc. which if not strictly observed, could result in damage to, or destruction of equipment, or loss of functional effectiveness. Cautions are highlighted as shown below:



WARNINGS and CAUTIONS SHOULD NEVER BE DISREGARDED.

The safety rules in this section are not intended to replace any rules or regulations of any applicable local, state, or federal governing organizations. Always follow your local lockout and tagout procedure when maintaining any radio equipment. The following information is intended to be used in conjunction with other rules or regulations already in existence. It is important to read all of the safety information contained in this section before installing or operating the Radio Control System.

2.0 CRITICAL INSTALLATION CONSIDERATIONS



WARNING

PRIOR TO INSTALLATION AND OPERATION OF THIS EQUIPMENT, READ AND DEVELOP AN UNDERSTANDING OF THE CONTENTS OF THIS MANUAL AND THE OPERATION MANUAL OF THE EQUIPMENT OR DEVICE TO WHICH THIS EQUIPMENT WILL BE INTERFACED. FAILURE TO FOLLOW THIS WARNING COULD RESULT IN SERIOUS INJURY OR DEATH AND DAMAGE TO EQUIPMENT.

ALL EQUIPMENT MUST HAVE A MAINLINE CONTACTOR INSTALLED AND ALL TRACKED CRANES, HOISTS, LIFTING DEVICES AND SIMILAR EQUIPMENT MUST HAVE A BRAKE INSTALLED. FAILURE TO FOLLOW THIS WARNING COULD RESULT IN SERIOUS INJURY OR DEATH AND DAMAGE TO EQUIPMENT.

AN AUDIBLE AND/OR VISUAL WARNING MEANS MUST BE PROVIDED ON ALL REMOTE CONTROLLED EQUIPMENT AS REQUIRED BY CODE, REGULATION, OR INDUSTRY STANDARD. THESE AUDIBLE AND/OR VISUAL WARNING DEVICES MUST MEET ALL GOVERNMENTAL REQUIREMENTS. FAILURE TO FOLLOW THIS WARNING COULD RESULT IN SERIOUS INJURY OR DEATH AND DAMAGE TO EQUIPMENT.

FOLLOW YOUR LOCAL LOCKOUT TAGOUT PROCEDURE BEFORE MAINTAINING ANY REMOTE CONTROLLED EQUIPMENT. ALWAYS REMOVE ALL ELECTRICAL POWER FROM THE CRANE, HOIST, LIFTING DEVICE OR SIMILAR EQUIPMENT BEFORE ATTEMPTING ANY INSTALLATION PROCEDURES. DE-ENERGIZE AND TAGOUT ALL SOURCES OF ELECTRICAL POWER BEFORE TOUCH-TESTING ANY EQUIPMENT. FAILURE TO FOLLOW THIS WARNING COULD RESULT IN SERIOUS INJURY OR DEATH AND DAMAGE TO EQUIPMENT.

THE DIRECT OUTPUTS OF THIS PRODUCT ARE NOT DESIGNED TO INTERFACE DIRECTLY TO TWO STATE SAFETY CRITICAL MAINTAINED FUNCTIONS, I.E., MAGNETS, VACUUM LIFTS, PUMPS, EMERGENCY EQUIPMENT, ETC. A MECHANICALLY LOCKING INTERMEDIATE RELAY SYSTEM WITH SEPARATE POWER CONSIDERATIONS MUST BE PROVIDED. FAILURE TO FOLLOW THIS WARNING COULD RESULT IN SERIOUS INJURY OR DEATH OR DAMAGE TO EQUIPMENT.



WARNING

SUBSTITUTION OF COMPONENTS MAY IMPAIR INTRINSIC SAFETY.

2.1 GENERAL

Radio controlled material handling equipment operates in several directions. Cranes, hoists, lifting devices and other material handling equipment can be large, and operate at high speeds. Quite frequently, the equipment is operated in areas where people are working in close proximity to the material handling equipment. **The operator must exercise extreme caution at all times.** Workers must constantly be alert to avoid accidents. The following recommendations have been included to indicate how careful and thoughtful actions may prevent injuries, damage to equipment, or even save a life.

2.2 PERSONS AUTHORIZED TO OPERATE RADIO CONTROLLED EQUIPMENT

Only properly trained persons designated by management should be permitted to operate radio controlled equipment.

Radio controlled cranes, hoists, lifting devices and other material handling equipment should not be operated by any person who cannot read or understand signs, notices and operating instructions that pertain to the equipment.

Radio controlled equipment should not be operated by any person with insufficient eyesight or hearing or by any person who may be suffering from a disorder or illness, is taking any medication that may cause loss of equipment control, or is under the influence of alcohol or drugs.

2.3 SAFETY INFORMATION AND RECOMMENDED TRAINING FOR RADIO CONTROLLED EQUIPMENT OPERATORS

Anyone being trained to operate radio controlled equipment should possess as a minimum the following knowledge and skills before using the radio controlled equipment.

The operator should:

- have knowledge of hazards pertaining to equipment operation
- have knowledge of safety rules for radio controlled equipment
- have the ability to judge distance of moving objects
- know how to properly test prior to operation
- be trained in the safe operation of the radio transmitter as it pertains to the crane, hoist, lifting device or other material handling equipment being operated
- have knowledge of the use of equipment warning lights and alarms
- have knowledge of the proper storage space for a radio control transmitter when not in use
- be trained in transferring a radio control transmitter to another person
- be trained how and when to report unsafe or unusual operating conditions
- test the transmitter emergency stop and all warning devices prior to operation; testing should be done on each shift, without a load
- be thoroughly trained and knowledgeable in proper and safe operation of the crane, hoist, lifting device, or other material handling equipment that utilizes the radio control
- know how to keep the operator and other people clear of lifted loads and to avoid “pinch” points
- continuously watch and monitor status of lifted loads
- know and follow cable and hook inspection procedures
- know and follow the local lockout and tagout procedures when servicing radio controlled equipment
- know and follow all applicable operating and maintenance manuals, safety procedures, regulatory requirements, and industry standards and codes

The operator shall not:

- lift or move more than the rated load

- operate the material handling equipment if the direction of travel or function engaged does not agree with what is indicated on the controller
- use the crane, hoist or lifting device to lift, support or transport people
- lift or carry any loads over people
- operate the crane, hoist or lifting device unless all persons, including the operator, are and remain clear of the supported load and any potential pinch points
- operate a crane, hoist or lifting device when the device is not centered over the load
- operate a crane, hoist or lifting device if the chain or wire rope is not seated properly in the sprockets, drum or sheave
- operate any damaged or malfunctioning crane, hoist, lifting device or other material handling equipment
- change any settings or controls without authorization and proper training
- remove or obscure any warning or safety labels or tags
- leave any load unattended while lifted
- leave power on the radio controlled equipment when the equipment is not in operation
- operate any material handling equipment using a damaged controller because the unit may be unsafe
- operate manual motions with other than manual power
- operate radio controlled equipment when low battery indicator is on



THE OPERATOR SHOULD NOT ATTEMPT TO REPAIR ANY RADIO CONTROLLER. IF ANY PRODUCT PERFORMANCE OR SAFETY CONCERNS ARE OBSERVED, THE EQUIPMENT SHOULD IMMEDIATELY BE TAKEN OUT OF SERVICE AND BE REPORTED TO THE SUPERVISOR. DAMAGED AND INOPERABLE RADIO CONTROLLER EQUIPMENT SHOULD BE RETURNED TO MAGNETEK FOR EVALUATION AND REPAIR. FAILURE TO FOLLOW THIS WARNING COULD RESULT IN SERIOUS INJURY OR DEATH AND DAMAGE TO EQUIPMENT.

2.4 TRANSMITTER UNIT

Transmitter switches should never be mechanically blocked ON or OFF. When not in use, the operator should turn the transmitter OFF. A secure storage space should be provided for the transmitter unit, and the transmitter unit should always be placed there when not in use. This precaution will help prevent unauthorized people from operating the material handling equipment.

Spare transmitters should be stored in a secure storage space and only removed from the storage space after the current transmitter in use has been turned OFF, taken out of the service area and secured.

2.5 PRE-OPERATION TEST

At the start of each work shift, or when a new operator takes control of the equipment, operators should do, as a minimum, the following steps before making lifts with any crane or hoist:

Test all warning devices.

Test all direction and speed controls.

Test the transmitter emergency stop.

2.6 HANDLING BATTERIES



KNOW AND FOLLOW PROPER BATTERY HANDLING, CHARGING AND DISPOSAL PROCEDURES. IMPROPER BATTERY PROCEDURES CAN CAUSE BATTERIES TO EXPLODE OR DO OTHER SERIOUS DAMAGE. FAILURE TO FOLLOW THIS WARNING COULD RESULT IN SERIOUS INJURY OR DEATH AND DAMAGE TO EQUIPMENT.

Use only batteries approved by Magnetek for the specific product.

Do not dispose of a battery pack in fire; it may explode.

Do not attempt to open the battery pack.

Do not short circuit the battery.

Do not use sharp tools to remove the battery pack or the cells.

Keep the battery pack environment cool during storage (i.e., not in direct sunlight or close to a heating source).

2.7 BATTERY DISPOSAL

Before disposing of batteries consult local and governmental regulatory requirements for proper disposal procedure.

2.8 SPECIFIC CONDITIONS OF SAFE USE



WARNING

POTENTIAL ELECTROSTATIC CHARGING HAZARD. SEE INSTRUCTIONS.

The MLTX2 has a maximum measured capacitance from housing and/or accessory to ground of 13pF. When possible, care should be taken to reduce the potential for generation of static electricity, such as:

- Controlling the work environment humidity level to minimize generation of static electricity
- Protect the transmitter from direct airflow
- Touch the transmitter with an insulating object or glove whenever possible
- Use in conjunction with gas detection monitoring
- Do not use in an area that is known to be a static electricity hazard

Additional information on electrostatics can be found in EN TR50404 and IEC/TR60079-32. Joysticks used in the transmitter may have >10% by mass of aluminum. The bulk of this material will be inside the transmitter and will not be accessible.

3.0 MLTX2 TRANSMITTER STANDARD CONFIGURATION AND OPERATION



WARNING

BEFORE OPERATING THE TRANSMITTER, FAMILIARIZE YOURSELF WITH ALL SAFETY INFORMATION IN THIS MANUAL, THE CORRESPONDING RECEIVER SYSTEM MANUAL, APPROPRIATE MANUAL SUPPLEMENTS AND ANY OTHER LOCAL, STATE, OR FEDERAL RULES OR REGULATIONS ALREADY IN EXISTENCE. FAILURE TO FOLLOW THIS WARNING COULD RESULT IN SERIOUS INJURY OR DEATH AND DAMAGE TO EQUIPMENT.

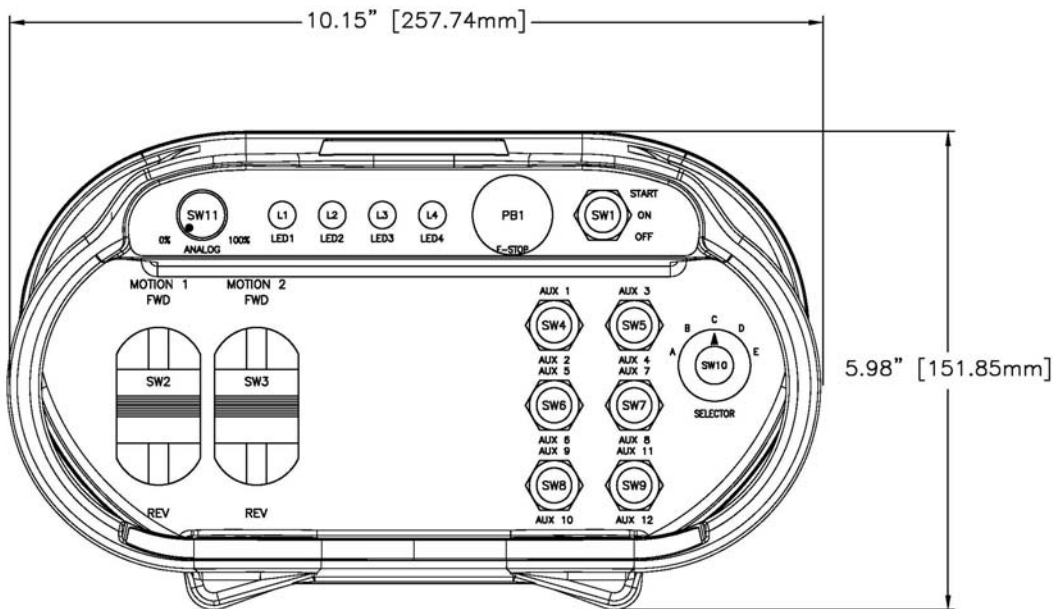

Figure 1: Typical MLTX2 Configuration

3.1 INSTALLING BATTERY PACK

Prior to utilizing the MLTX2 transmitter, the battery pack must be installed.

3.1.1 Approved Batteries for Intrinsically Safe Operation

The MLTX2 transmitter has been tested and approved for intrinsically safe operation with the following AA (LR6) size batteries:

Duracell	MN1500
Duracell	PC1500
Energizer	E91
Panasonic	LR6XWA
Rayovac	815

Use only the above battery manufacturers and part numbers as replacement batteries to maintain intrinsically safe operation.

**WARNING**

ONLY OPERATE THE TRANSMITTER IN HAZARDOUS ENVIRONMENTS WITH THE APPROVED BATTERIES. FAILURE TO USE THE APPROVED BATTERIES COULD RESULT IN SERIOUS INJURY OR DEATH AND DAMAGE TO EQUIPMENT. ONLY USE FOUR BATTERIES OF THE SAME MANUFACTURER AND MODEL NUMBER.

3.1.2 Intrinsically Safe Alkaline Battery Pack

The Intrinsically Safe MLTX2 comes standard with an intrinsically safe battery pack that holds four disposable AA alkaline batteries.

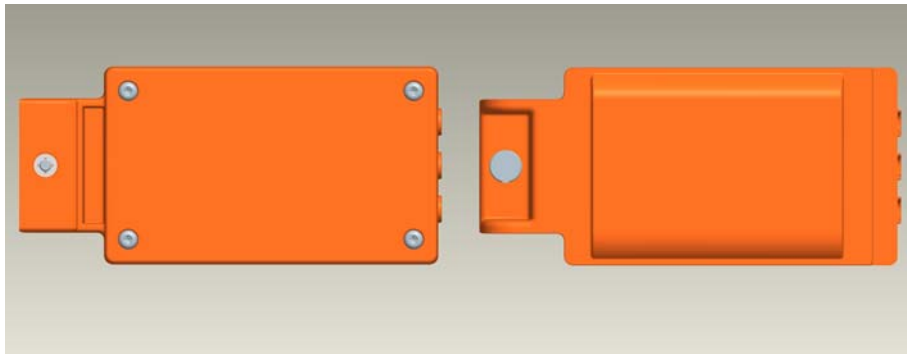

Figure 2: Intrinsically Safe Battery Pack (Top and Bottom Views)

To change the alkaline batteries in the battery pack, loosen the T10 star bit screws completely and remove the battery pack lid. Replace all the batteries with new ones.

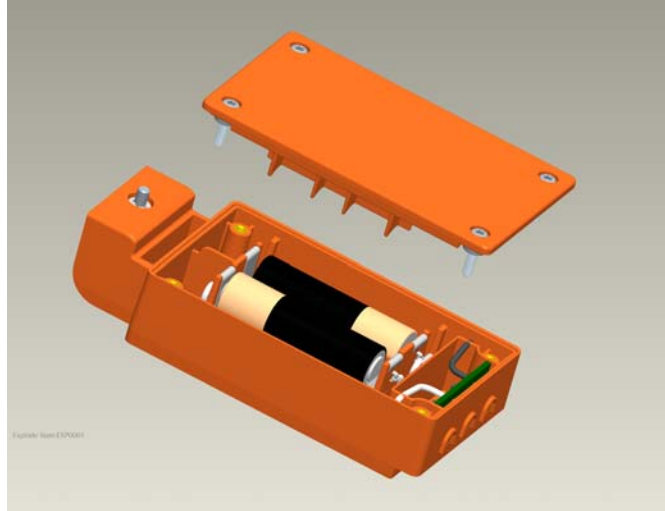

Figure 3: Separated Alkaline Battery Pack

When reinserting the lid onto the outer housing, make sure that the lid aligns with the outer housing and secure all four T10 star bit screws. When placing the battery pack into the MLTX2 battery pocket, ensure that the pack is fully seated and that the thumb screw is tightened down to hold the battery pack in place.

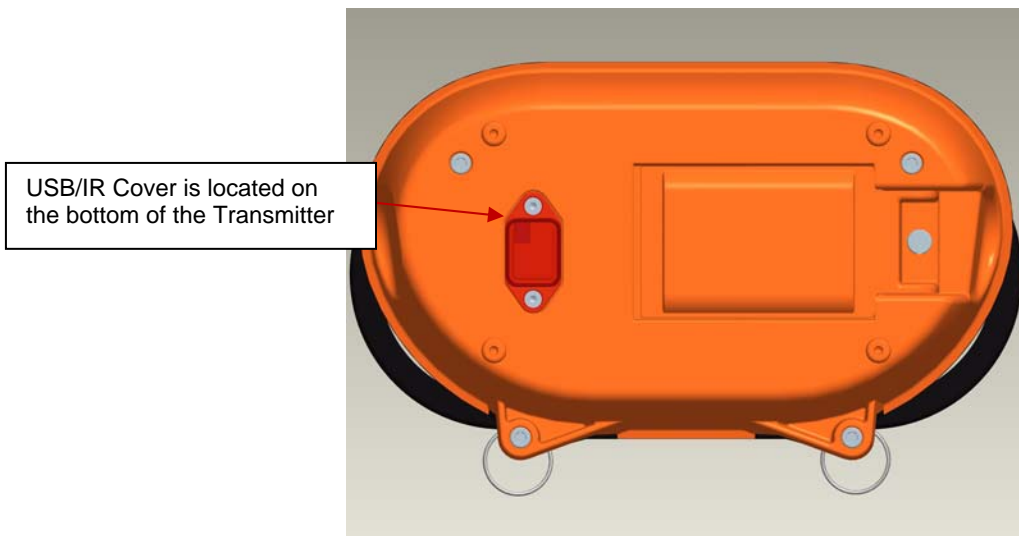

Figure 4: Installation of Battery Pack into MLTX2 Transmitter

NOTE: The Intrinsically Safe battery pack must be secured in place with the thumb screw. Failure to secure the thumb screw will not allow the battery pack to stay securely in place.

3.2 TURNING THE TRANSMITTER ON AND OFF

The MLTX2 uses both a three position toggle switch labeled OFF-ON-START and a Machine Stop switch to turn the transmitter on or off.



Figure 5: Machine Stop Switch and OFF-ON-START Toggle

3.2.1 Turning On the Transmitter

First, the Machine Stop switch must be in the raised position (pulled out). Next, push the OFF-ON-START toggle switch to the START position and release it once the Status LED lights up as a solid green color. Following the Status LED turning on and illuminating green, the unit will perform a routine initialization.

During initialization, the MLTX2 scans for any switches or motions that may be on during power up. If any switches or motions are on, the failure will be displayed as a solid red Status LED, and then the MLTX2 will power itself down.

After a successful initialization, the MLTX2 will enter normal operation mode and display the normal operating status LED indications. See Section 3.5 for more information on the normal operation mode with standard status LED.

3.2.2 Pulling In the Machine Stop Relay

Once the MLTX2 has been turned on (as described in Sections 3.2.1 or 3.2.2) and in the Normal Operating Mode, the Machine Stop relay in the receiver can be pulled in by pushing the OFF-ON-START toggle switch to the START position and then releasing.

NOTE: You must release the OFF-ON-START switch to the ON position after the unit is powered up, then push to the START position a second time to pull in the Machine Stop relay.

3.2.3 Turning Off the Transmitter

The transmitter can be turned off by pressing the OFF-ON-START toggle switch down to the OFF position. Once turned off, the Machine Stop relay in the receiver is immediately opened.

NOTE: If the unit has a standard status LED, it will illuminate solid red during the transmitter's power down process. Once the power down process is complete, the transmitter will turn off and the status LED will not be on.

NOTE: Depressing the Machine Stop switch will also turn the transmitter off and open the Machine Stop relay in the receiver. See Section 3.3 for more information on the Machine Stop switch.

3.3 MACHINE STOP SWITCH (FOR EMERGENCY STOPPING ONLY)

When the Machine Stop switch is depressed, the Machine Stop relay in the receiver is immediately opened.

Under normal operating conditions, the Machine Stop switch must be in the raised position or the transmitter and system will not operate.

NOTE: The Machine Stop Switch is to be used for emergency stopping only, not for normal system shut down.

3.4 STATUS LED

The standard MLTX2 transmitter includes a status LED to let the operator know that the unit is functioning and if the battery level is low.

3.5 NORMAL OPERATING MODE WITH STANDARD STATUS LED

In normal operating mode, the MLTX2 utilizes the status LED to communicate the watch dog timer within the CPU of the transmitter and when the battery level is low.

3.5.1 Watch Dog Indicator (Steady Blinking Status LED)

The blinking LED represents the watch dog timer within the CPU of the unit.

NOTE: The LED should be continuously blinking at all times. If the LED is not blinking the transmitter will need to be rebooted to operate properly.

3.5.2 Switch Change Indicator (Rapidly Blinking Status LED)

When a switch is actuated or a switch status changes, the status LED will blink rapidly during the change.

NOTE: If a joystick, rotary switch, or auxiliary switch is held in position or latched, the status LED will return to the steady watch dog indicator blinking state.

3.5.3 Low Battery Level Indicator (Blinking Red Status LED)

The status LED will turn red when the battery level drops below 10%. The status LED will continue blinking for the watch dog indicator and switch change indicator status.

3.6 JOYSTICKS AND PADDLES/LEVERS

To activate the desired motor functions, operate the Joystick or Paddle/Lever that corresponds to the desired motion.

To activate higher speed functions for those transmitter models so equipped, operate the Joystick or Paddle/Lever further to activate the desired speed.

3.7 ROTARY SELECTOR SWITCH

The rotary selector switch can be used to select various modes of operation.

A rotary switch can have 2 to 12 positions to select from.

3.8 AUXILIARY SWITCHES

These switches activate special function relays that control items such as grab attachments, magnets, lights, etc.

The auxiliary switches can be momentary or latched.

3.9 CONNECTING THE MLTX2 TO A COMPUTER



WARNING

TO PREVENT IGNITION OF FLAMMABLE OR COMBUSTIBLE ATMOSPHERES, AND TO AVOID COMPROMISING INTRINSIC SAFETY OF THE EQUIPMENT, READ, UNDERSTAND, AND ADHERE TO THE LIVE MAINTENANCE PROCEDURES BELOW.

Only trained Magnetek service personnel are permitted to connect the MLTX2 to a computer. Contact Magnetek Service if service to the product is required.



WARNING

PROGRAMMING THROUGH THE USB PORT IS TO BE DONE SOLELY BY MAGENETK SERVICE PERSONNEL. FAILURE TO FOLLOW THIS WARNING COULD RESULT IN SERIOUS INJURY OR DEATH, AND DAMAGE TO EQUIPMENT.

4.0 TRANSMITTER SETUP

The built-in dip switch block can adjust the RF channel. All other settings can only be changed at the factory.

4.1 TRANSMITTER SETUP SETTINGS WITH STANDARD STATUS LED



WARNING

TO PREVENT IGNITION OF FLAMMABLE OR COMBUSTIBLE ATMOSPHERES, AND TO AVOID COMPROMISING INTRINSIC SAFETY OF THE EQUIPMENT, READ, UNDERSTAND, AND ADHERE TO THE LIVE MAINTENANCE PROCEDURES BELOW.

The only settings that can be adjusted via the dipswitch block is the RF channel setting. This dip switch block is visible through the IR window (see Figure 6).

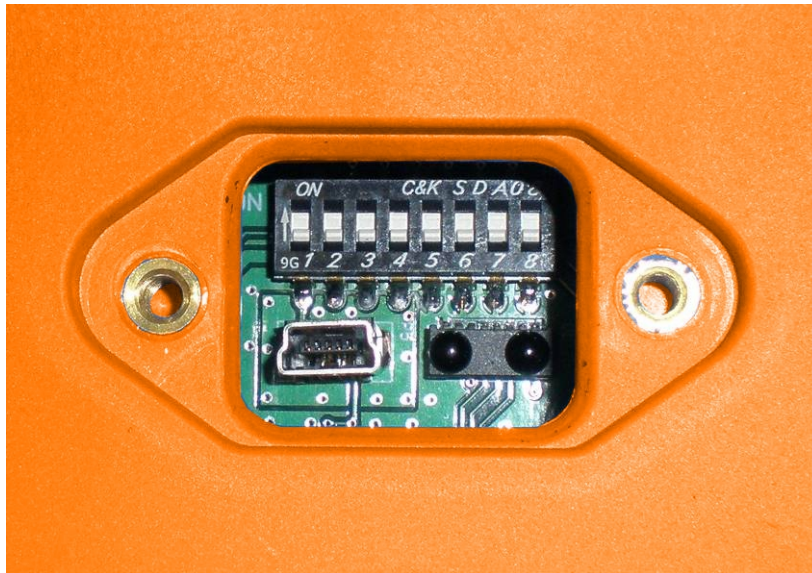

Figure 6: Dip switch block as viewed through IR port

NOTE: The dip switch block switches are oriented so that the Off position is next to the number designator and the On position is up or away from the number designator.

Regardless of which radio frequency the transmitter was equipped with, the RF channel dip switch settings are the same. Refer to Sections 5.2 and 5.3 for details on the specific RF channel details for the radio frequency that the transmitter is equipped with.



WARNING

ONLY PERFORM SETTING CHANGES TO THE DIP SWITCH BLOCK THROUGH THE IR PORT IN A NON-HAZARDOUS ENVIRONMENT OR "SAFE" ZONE. FAILURE TO FOLLOW THIS WARNING COULD RESULT IN SERIOUS INJURY OR DEATH, AND DAMAGE TO EQUIPMENT.

The following figure details the dip switch positions for each RF channel.

DIPSWITCH POSITIONS

CHANNEL	SW4	SW5	SW6	SW7	SW8
1	UP	UP	UP	UP	UP
2	DOWN	UP	UP	UP	UP
3	UP	DOWN	UP	UP	UP
4	DOWN	DOWN	UP	UP	UP
5	UP	UP	DOWN	UP	UP
6	DOWN	UP	DOWN	UP	UP
7	UP	DOWN	DOWN	UP	UP
8	DOWN	DOWN	DOWN	UP	UP
9	UP	UP	UP	DOWN	UP
10	DOWN	UP	UP	DOWN	UP
11	UP	DOWN	UP	DOWN	UP
12	DOWN	DOWN	UP	DOWN	UP
13	UP	UP	DOWN	DOWN	UP
14	DOWN	UP	DOWN	DOWN	UP
15	UP	DOWN	DOWN	DOWN	UP
16	DOWN	DOWN	DOWN	DOWN	UP
17	UP	UP	UP	UP	DOWN
18	DOWN	UP	UP	UP	DOWN
19	UP	DOWN	UP	UP	DOWN
20	DOWN	DOWN	UP	UP	DOWN
21	UP	UP	DOWN	UP	DOWN
22	DOWN	UP	DOWN	UP	DOWN
23	UP	DOWN	DOWN	UP	DOWN
24	DOWN	DOWN	DOWN	UP	DOWN
25	UP	UP	UP	DOWN	DOWN
26	DOWN	UP	UP	DOWN	DOWN
27	UP	DOWN	UP	DOWN	DOWN
28	DOWN	DOWN	UP	DOWN	DOWN
29	UP	UP	DOWN	DOWN	DOWN
30	DOWN	UP	DOWN	DOWN	DOWN
31	UP	DOWN	DOWN	DOWN	DOWN
32	DOWN	DOWN	DOWN	DOWN	DOWN

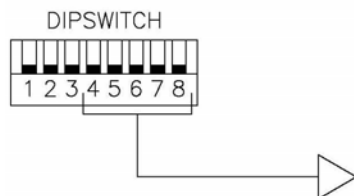

Figure 7: Dip Switch Positions for RF Channel Selection

The dip switch settings will take effect upon the next power cycle of the transmitter.

5.0 TRANSMITTER RF CHANNEL CONFIGURATION SETTINGS

The RF channel is set up by using the dip switch block as detailed in Section 4.1. Sections 5.2 and 5.3 show the channels and protocols available for each transmitter radio frequency option.

5.1 FCC/ATEX/IECEX STATEMENTS

Compliance Statement (Part 15.19)

This device complies with Part 15 of FCC rules.

Operation is subject to the following two conditions:

1. This device may not cause harmful interference, and
2. This device must accept any interference received, including interference that may cause undesired operation.

Warning (Part 15.21)

Changes or modifications not expressly approved by the party responsible for compliance should void the user's authority to operate the equipment.

This portable transmitter with its antenna complies with FCC's RF exposure limits for general population/uncontrolled exposure.

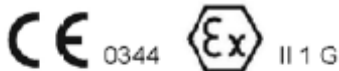

II 1 G Ex ia IIC T4 Ga
DEMKO 14 ATEX 1350799X
IECEX UL 14.0028 X
Ex ia IIC T4 Ga
-40°C ≤ Ta ≤ +40°C

STANDARDS COMPLIED WITH FOR ATEX/IECEX

EN 60079-0:2012
EN 60079-11:2012
EN 60079-26:2007
IEC 60079-0 6th edition
IEC 60079-11 6th edition
IEC 60079-26 2nd edition

5.2 CHANNEL AND FREQUENCY DESIGNATIONS BY COUNT

433 MHz: TMS and TDMA

Channel Count	Channel Designator	Actual Frequency
01)	01	433.000 MHz
02)	02	433.050 MHz
03)	03	433.100 MHz
04)	04	433.150 MHz
05)	05	433.200 MHz
06)	06	433.250 MHz
07)	07	433.300 MHz
08)	08	433.350 MHz
09)	09	433.400 MHz
10)	10	433.450 MHz
11)	11	433.500 MHz
12)	12	433.550 MHz
13)	13	433.600 MHz
14)	14	433.650 MHz
15)	15	433.700 MHz
16)	16	433.750 MHz
17)	17	433.800 MHz
18)	18	433.850 MHz
19)	19	433.900 MHz
20)	20	433.950 MHz
21)	21	434.000 MHz
22)	22	434.050 MHz
23)	23	434.100 MHz
24)	24	434.150 MHz
25)	25	434.200 MHz
26)	26	434.250 MHz
27)	27	434.300 MHz
28)	28	434.350 MHz
29)	29	434.400 MHz
30)	30	434.450 MHz
31)	31	434.500 MHz
32)	32	434.550 MHz

Table 1

5.3 OPTIONAL FREQUENCIES AND CHANNELS

433 MHz Telemotive Legacy Channel Set: TMS and TDMA

Channel Count	Channel Designator	Actual Frequency
01)	AK01	439.8 MHz
02)	AK02	439.6 MHz
03)	AK03	439.4 MHz
04)	AK04	439.2 MHz
05)	AK05	439.0 MHz
06)	AK06	438.8 MHz
07)	AK07	438.6 MHz
08)	AK08	438.4 MHz
09)	AK09	438.2 MHz
10)	AK10	438.0 MHz
11)	AK11	437.8 MHz
12)	AK12	437.6 MHz
13)	AK13	437.4 MHz
14)	AK14	437.2 MHz
15)	AK15	437.0 MHz
16)	AK16	436.8 MHz
17)	AK17	436.6 MHz
18)	AK18	436.4 MHz
19)	AK19	436.2 MHz
20)	AK20	436.0 MHz
21)	AKA00	433.125 MHz
22)	AKA01	433.325 MHz
23)	AKA02	433.525 MHz
24)	AKA03	433.725 MHz
25)	AKA04	433.925 MHz
26)	AKA05	434.125 MHz
27)	AKA06	434.325 MHz
28)	AKA07	434.525 MHz
29)	AKA08	434.725 MHz
30)	AK38	432.4 MHz
31)	AK50	430.0 MHz

Table 2

6.0 GENERAL TROUBLESHOOTING

Problems	Possible Reasons	Suggestions
Transmitter will not turn on	Batteries are dead or installed backwards; battery holder is damaged.	Replace the batteries and confirm they are installed according to the polarity marking in the battery pack. Inspect all battery pack contacts for damage. When installing the battery pack into the MLTX2, confirm it is installed with the label facing out.
	Transmitter is failing switch scan	Be sure all switches and motions are in the off position on startup. See Section 3.2 for more info.
	Transmitter Machine Stop Switch is down or pressed	Be sure the Machine Stop switch is pulled up.
Transmitter will not respond with the receiver	Incorrect system RF channel	Make sure the transmitter and receiver unit are both set to the same RF channel.
	Incorrect system access code	Make sure the transmitter and receiver both have the same access code.
	System out of range	Make sure that the startup procedure is initiated within 300 feet from the receiver location.
	The antenna on the receiver is missing, damaged, or improperly installed.	Inspect the antenna on the receiver for damage and try to locate the antenna in a location that is visible when operating the equipment at all times.

6.1 ASSEMBLY AND REPLACEMENT PARTS

If your transmitter ever needs repair, we always recommend that you have Magnetek perform the repair. If you need to refer to a parts list, refer to your transmitter's drawing that was included in the shipment of your transmitter. Please contact Magnetek's service department at 1.866.MAG.SERV for information regarding parts and service.

7.0 TECHNICAL SPECIFICATIONS

Environmental conditions, during operation:	-40°C to 40°C / 32°F to 104°F
Environmental conditions, storage:	-40°C to 40°C / 32°F to 104°F
Humidity:	0% to 95% noncondensing
Pressure:	700 to 1300 hPa (10.2 to 18.9 psi)
Ingress protection:	IP26