

# CAN-6

---

## Enrange CAN-6 Radio Receiver

---



**MAGNETEK**  
MATERIAL HANDLING  
**ENRANGE**

September 2011  
Part Number: 198-00244-1000-R1  
©Copyright 2011 Magnetek Material Handling

## Your New Radio Receiver

Thank you for your purchase of Magnetek's Enrange™ CAN-6 Radio Controller. Magnetek has set a whole new standard in wireless control performance, dependability, and value with this unique line of Radio Controllers.

If your product ever needs modification or service, please contact one of our representatives at the following locations:

### **U.S. Service Information**

For questions regarding service or technical information contact:

**1.866.MAG.SERV**  
**(1.866.624.7378)**

Magnetek, Inc.  
N49 W13650 Campbell Drive  
Menomonee Falls, WI 53051

**Telephone:** 1.800.288.8178

**Website:** [www.magnetekmobilehydraulic.com](http://www.magnetekmobilehydraulic.com)  
**e-mail:** [info@magnetekmh.com](mailto:info@magnetekmh.com)

#### **Fax Numbers:**

*Main:* 1.800.298.3503  
*Sales:* 1.262.783.3510  
*Service:* 1.262.783.3508

### **Canada Service Information:**

4090B Sladeview Crescent  
Mississauga, Ontario  
L5L 5Y5 Canada  
Phone: 1.800.792.7253  
Fax: 1.905.828.5707  
1.416.424.7617 (24/7 Service pager)

©2011 MAGNETEK

All rights reserved. This notice applies to all copyrighted materials included with this product, including, but not limited to, this manual and software embodied within the product. This manual is intended for the sole use of the person(s) to whom it was provided, and any unauthorized distribution of the manual or dispersal of its contents is strictly forbidden. This manual may not be reproduced in whole or in part by any means whatsoever without the expressed written permission of MAGNETEK.

## TABLE OF CONTENTS

1.0	INTRODUCTION .....	3
1.1	PRODUCT MANUAL SAFETY INFORMATION .....	3
1.2	WARNINGS and CAUTIONS.....	4
2.0	CRITICAL INSTALLATION CONSIDERATIONS .....	5
2.1	GENERAL .....	5
2.2	PERSONS AUTHORIZED TO OPERATE RADIO CONTROLLED EQUIPMENT .....	5
2.3	SAFETY INFORMATION & RECOMMENDED TRAINING FOR RADIO CONTROLLED EQUIPMENT OPERATORS.....	6
2.4	PRE-OPERATION TEST .....	7
3.0	CAN-6 RECEIVER INSTALLATION.....	8
3.1	PRE INSTALLATION .....	8
3.2	MECHANICAL DRAWINGS.....	8
3.3	INSTALLATION.....	10
3.4	REMOVAL OF CAN-6 FROM HOUSING .....	10
3.5	PIN OUT DIAGRAM AND DEFINITIONS .....	11
3.6	CAN-6 RECEIVER BLOCK DIAGRAM.....	13
4.0	CONFIGURING THE CAN-6 .....	14
4.1	SETTING ANTENNA TYPE .....	14
4.2	REMAINING BANK 1 DIP SWITCH SETTINGS.....	14
4.3	RECEIVER CHANNEL CONFIGURATION SETTINGS (DIP SWITCH BANK 2) .....	15
4.3.1	Channel Dip Switch Settings for 900MHz Part 15 .....	16
4.3.2	Channel Dip Switch Settings for 433MHz Part 15 .....	17
4.3.3	Channel Dip Switch Settings for 2.4GHz @ 50mW and 125mW .....	18
4.4	FCC STATEMENTS.....	19
5.0	NORMAL OPERATION .....	20
5.1	INITIALIZATION.....	20
5.2	NORMAL OPERATION.....	20
5.3	LED STATUS INDICATION .....	20
5.3.1	RF Messages LED (Top LED on CAN-6 Faceplate) .....	20
5.3.2	Signal Strength/Error Code LED (Bottom LED on CAN-6 Faceplate).....	21
6.0	TROUBLESHOOTING.....	22
6.1	TROUBLESHOOTING TABLE .....	22
6.2	ASSEMBLY AND REPLACEMENT PARTS .....	24

## 1.0 INTRODUCTION

Thank you for your purchase of Magnetek's Enrange® brand CAN-6 Radio Wireless Receiver.

These instructions are to be used as a reference for personnel operating the Enrange® brand CAN-6 Radio Wireless Receiver and the equipment that this Enrange® brand CAN-6 Radio Wireless Receiver is attached to.

The user of these instructions should have basic knowledge in the handling of electronic equipment.

## 1.1 PRODUCT MANUAL SAFETY INFORMATION

Magnetek, Inc. (Magnetek) offers a broad range of radio remote control products, control products and adjustable frequency drives, and industrial braking systems for overhead material handling applications. This manual has been prepared by Magnetek to provide information and recommendations for the installation, use, operation and service of Magnetek's material handling products and systems (Magnetek Products). Anyone who uses, operates, maintains, services, installs or owns Magnetek Products should know, understand and follow the instructions and safety recommendations in this manual for Magnetek Products.

The recommendations in this manual do not take precedence over any of the following requirements relating to cranes, hoists and lifting devices:

- Instructions, manuals, and safety warnings of the manufacturers of the equipment where the radio system is used,
- Plant safety rules and procedures of the employers and the owners of facilities where the Magnetek Products are being used,
- Regulations issued by the Occupational Health and Safety Administration (OSHA),
- Applicable local, state or federal codes, ordinances, standards and requirements, or
- Safety standards and practices for the overhead material handling industry.

This manual does not include or address the specific instructions and safety warnings of these manufacturers or any of the other requirements listed above. It is the responsibility of the owners, users and operators of the Magnetek Products to know, understand and follow all of these requirements. It is the responsibility of the owner of the Magnetek Products to make its employees aware of all of the above listed requirements and to make certain that all operators are properly trained. **No one should use Magnetek Products prior to becoming familiar with and being trained in these requirements.**

### WARRANTY INFORMATION

FOR INFORMATION ON MAGNETEK'S PRODUCT WARRANTIES BY PRODUCT TYPE, PLEASE VISIT [WWW.MAGNETEKMOBILEHYDRAULIC.COM](http://WWW.MAGNETEKMOBILEHYDRAULIC.COM).

## 1.2 WARNINGS and CAUTIONS

Throughout this document WARNING and CAUTION statements have been deliberately placed to highlight items critical to the protection of personnel and equipment.

**WARNING – A warning highlights an essential operating or maintenance procedure, practice, etc. which if not strictly observed, could result in injury or death of personnel, or long term physical hazards. Warnings are highlighted as shown below:**



**CAUTION – A caution highlights an essential operating or maintenance procedure, practice, etc. which if not strictly observed, could result in damage to, or destruction of equipment, or loss of functional effectiveness. Cautions are highlighted as shown below:**



**WARNINGS and CAUTIONS SHOULD NEVER BE DISREGARDED.**

The safety rules in this section are not intended to replace any rules or regulations of any applicable local, state, or federal governing organizations. Always follow your local lockout and tagout procedure when maintaining any radio equipment. The following information is intended to be used in conjunction with other rules or regulations already in existence. It is important to read all of the safety information contained in this section before installing or operating the Radio Control System.

## 2.0 CRITICAL INSTALLATION CONSIDERATIONS



### WARNING

PRIOR TO INSTALLATION AND OPERATION OF THIS EQUIPMENT, READ AND DEVELOP AN UNDERSTANDING OF THE CONTENTS OF THIS MANUAL AND THE OPERATION MANUAL OF THE EQUIPMENT OR DEVICE TO WHICH THIS EQUIPMENT WILL BE INTERFACED. FAILURE TO FOLLOW THIS WARNING COULD RESULT IN SERIOUS INJURY OR DEATH AND DAMAGE TO EQUIPMENT.

ALL EQUIPMENT MUST HAVE A MAINLINE CONTACTOR INSTALLED AND ALL TRACKED CRANES, HOISTS, LIFTING DEVICES AND SIMILAR EQUIPMENT MUST HAVE A BRAKE INSTALLED. FAILURE TO FOLLOW THIS WARNING COULD RESULT IN SERIOUS INJURY OR DEATH AND DAMAGE TO EQUIPMENT.

AN AUDIBLE AND/OR VISUAL WARNING MEANS MUST BE PROVIDED ON ALL REMOTE CONTROLLED EQUIPMENT AS REQUIRED BY CODE, REGULATION, OR INDUSTRY STANDARD. THESE AUDIBLE AND/OR VISUAL WARNING DEVICES MUST MEET ALL GOVERNMENTAL REQUIREMENTS. FAILURE TO FOLLOW THIS WARNING COULD RESULT IN SERIOUS INJURY OR DEATH AND DAMAGE TO EQUIPMENT.

FOLLOW YOUR LOCAL LOCKOUT TAGOUT PROCEDURE BEFORE MAINTAINING ANY REMOTE CONTROLLED EQUIPMENT. ALWAYS REMOVE ALL ELECTRICAL POWER FROM THE CRANE, HOIST, LIFTING DEVICE OR SIMILAR EQUIPMENT BEFORE ATTEMPTING ANY INSTALLATION PROCEDURES. DE-ENERGIZE AND TAGOUT ALL SOURCES OF ELECTRICAL POWER BEFORE TOUCH-TESTING ANY EQUIPMENT. FAILURE TO FOLLOW THIS WARNING COULD RESULT IN SERIOUS INJURY OR DEATH AND DAMAGE TO EQUIPMENT.

THE DIRECT OUTPUTS OF THIS PRODUCT ARE NOT DESIGNED TO INTERFACE DIRECTLY TO TWO STATE SAFETY CRITICAL MAINTAINED FUNCTIONS, I.E., MAGNETS, VACUUM LIFTS, PUMPS, EMERGENCY EQUIPMENT, ETC. A MECHANICALLY LOCKING INTERMEDIATE RELAY SYSTEM WITH SEPARATE POWER CONSIDERATIONS MUST BE PROVIDED. FAILURE TO FOLLOW THIS WARNING COULD RESULT IN SERIOUS INJURY OR DEATH OR DAMAGE TO EQUIPMENT.

## 2.1 GENERAL

Radio controlled material handling equipment operates in several directions. Cranes, hoists, lifting devices and other material handling equipment can be large, and operate at high speeds. Quite frequently, the equipment is operated in areas where people are working in close proximity to the material handling equipment. **The operator must exercise extreme caution at all times.** Workers must constantly be alert to avoid accidents. The following recommendations have been included to indicate how careful and thoughtful actions may prevent injuries, damage to equipment, or even save a life.

## 2.2 PERSONS AUTHORIZED TO OPERATE RADIO CONTROLLED EQUIPMENT

Only properly trained persons designated by management should be permitted to operate radio controlled equipment.

Radio controlled cranes, hoists, lifting devices and other material handling equipment should not be operated by any person who cannot read or understand signs, notices and operating instructions that pertain to the equipment.

Radio controlled equipment should not be operated by any person with insufficient eyesight or hearing or by any person who may be suffering from a disorder or illness, is taking any medication that may cause loss of equipment control, or is under the influence of alcohol or drugs.

## 2.3 SAFETY INFORMATION & RECOMMENDED TRAINING FOR RADIO CONTROLLED EQUIPMENT OPERATORS

Anyone being trained to operate radio controlled equipment should possess as a minimum the following knowledge and skills before using the radio controlled equipment.

### The operator should:

- have knowledge of hazards pertaining to equipment operation
- have knowledge of safety rules for radio controlled equipment
- have the ability to judge distance of moving objects
- know how to properly test prior to operation
- be trained in the safe operation of the radio receiver as it pertains to the crane, hoist, lifting device or other material handling equipment being operated
- have knowledge of the use of equipment warning lights and alarms
- have knowledge of the proper storage space for a radio control receiver when not in use
- be trained in transferring a radio control receiver to another person
- be trained how and when to report unsafe or unusual operating conditions
- test the receiver emergency stop and all warning devices prior to operation; testing should be done on each shift, without a load
- be thoroughly trained and knowledgeable in proper and safe operation of the crane, hoist, lifting device, or other material handling equipment that utilizes the radio control
- know how to keep the operator and other people clear of lifted loads and to avoid “pinch” points
- continuously watch and monitor status of lifted loads
- know and follow cable and hook inspection procedures
- know and follow the local lockout and tagout procedures when servicing radio controlled equipment
- know and follow all applicable operating and maintenance manuals, safety procedures, regulatory requirements, and industry standards and codes

### The operator shall not:

- lift or move more than the rated load
- operate the material handling equipment if the direction of travel or function engaged does not agree with what is indicated on the controller
- use the crane, hoist or lifting device to lift, support or transport people
- lift or carry any loads over people
- operate the crane, hoist or lifting device unless all persons, including the operator, are and remain clear of the supported load and any potential pinch points
- operate a crane, hoist or lifting device when the device is not centered over the load

- operate a crane, hoist or lifting device if the chain or wire rope is not seated properly in the sprockets, drum or sheave
- operate any damaged or malfunctioning crane, hoist, lifting device or other material handling equipment
- change any settings or controls without authorization and proper training
- remove or obscure any warning or safety labels or tags
- leave any load unattended while lifted
- leave power on the radio controlled equipment when the equipment is not in operation
- operate any material handling equipment using a damaged controller because the unit may be unsafe
- operate manual motions with other than manual power
- operate radio controlled equipment when low battery indicator is on



## **WARNING**

THE OPERATOR SHOULD NOT ATTEMPT TO REPAIR ANY RADIO CONTROLLER. IF ANY PRODUCT PERFORMANCE OR SAFETY CONCERNS ARE OBSERVED, THE EQUIPMENT SHOULD IMMEDIATELY BE TAKEN OUT OF SERVICE AND BE REPORTED TO THE SUPERVISOR. DAMAGED AND INOPERABLE RADIO CONTROLLER EQUIPMENT SHOULD BE RETURNED TO MAGNETEK FOR EVALUATION AND REPAIR. FAILURE TO FOLLOW THIS WARNING COULD RESULT IN SERIOUS INJURY OR DEATH AND DAMAGE TO EQUIPMENT.

### **2.4 PRE-OPERATION TEST**

At the start of each work shift, or when a new operator takes control of the crane, operators should do, as a minimum, the following steps before making lifts with any crane or hoist:

Test all warning devices.

**Test all direction and speed controls.**

Test the receiver emergency stop.



### 3.0 CAN-6 RECEIVER INSTALLATION



## WARNING

BEFORE OPERATING THE RECEIVER, FAMILIARIZE YOURSELF WITH ALL SAFETY INFORMATION IN THIS MANUAL, APPROPRIATE MANUAL SUPPLEMENTS AND ANY OTHER LOCAL, STATE, OR FEDERAL RULES OR REGULATIONS ALREADY IN EXISTENCE. FAILURE TO FOLLOW THIS WARNING COULD RESULT IN SERIOUS INJURY OR DEATH AND DAMAGE TO EQUIPMENT.

### 3.1 PRE INSTALLATION

1. The transmitter and receiver access code and channel must match before the system will communicate.
2. Be aware of other radio channels in the surrounding area - set your system to a unique channel.
3. Make sure that your equipment is working properly in manual mode prior to system installation.
4. Make sure the power to the receiver is the correct DC voltage.
5. Disconnect equipment power prior to system installation.

### 3.2 MECHANICAL DRAWINGS

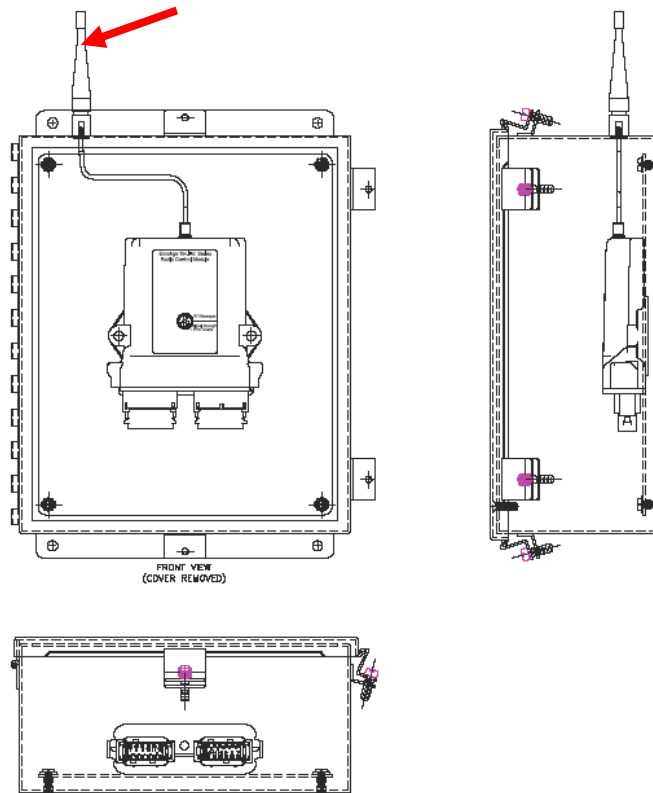
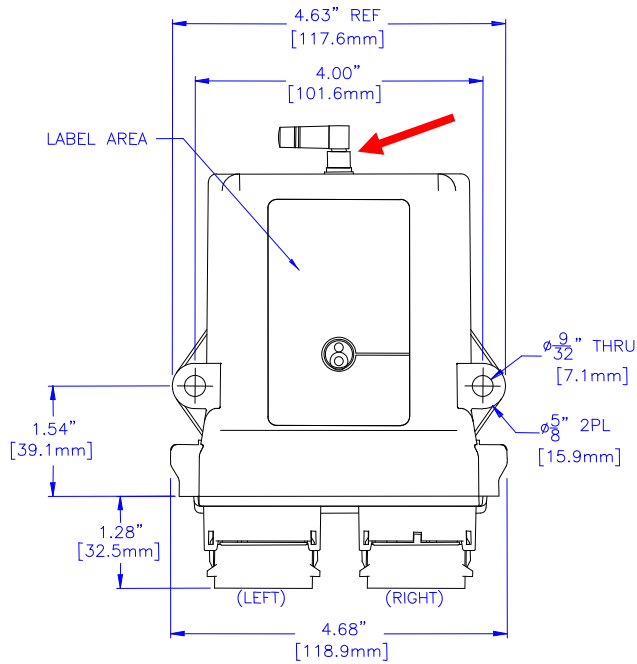
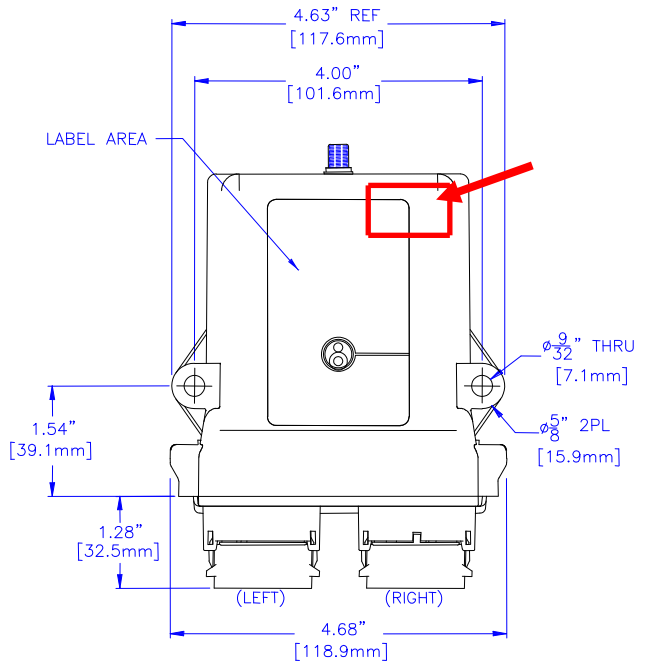

Figure 01: Remote Antenna (marked in red)



**Figure 02: CAN-6 with external antenna (red)**



**Figure 03: CAN-6 (900 MHz version only) with internal antenna (red)**

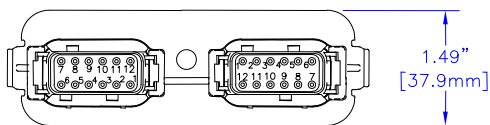

**Figure 04: CAN-6 with Con1 and Con2 connectors**

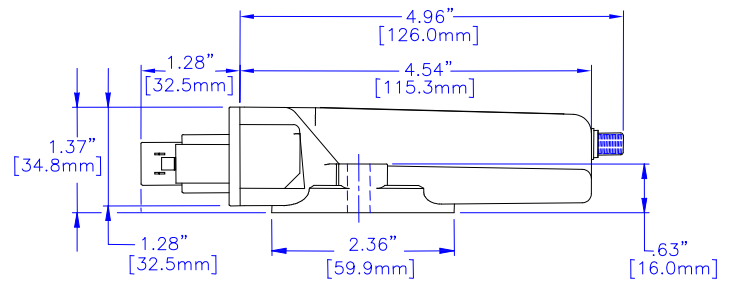

**Figure 05: CAN-6 Side View**

### 3.3 INSTALLATION

1. Determine the location of your antenna from Figures 01-03 (the antenna is designated with the red arrow). **Be sure to mount the receiver antenna in direct line-of-sight of the operator and free from all obstructions.**
2. Do not mount the receiver near high levels of electric noise, such as an unshielded variable frequency drive, as it may cause minor interference. When mounting the CAN-6 near an unshielded variable frequency drive, **Magnetek typically recommends that the CAN-6 and all antenna cable routing be mounted a minimum of 24 inches from all unshielded variable frequency drives and cables.**
3. Allow adequate room for mounting the receiver. Make sure to allow a minimum of 5" between the connector and the nearest surface to allow for cable harness connections.
4. For best reception and to help protect connectors from moisture and water damage, mount the receiver in an upright position.
5. If obstructions cannot be cleared, or the unit must be mounted inside a metal enclosure, the remote antenna should be used (see Figure 01).
6. Do not enclose the antenna in steel. For best reception, keep all metal objects away from the antenna. **Consult the factory for more information regarding your application.**
7. The supply power to the CAN-6 system must have a master disconnect and should be fused.

*NOTE: Magnetek strongly recommends the use of external fuses and circuit disconnects for all CAN-6 Receivers. Consult factory for more information.*

### 3.4 REMOVAL OF CAN-6 FROM HOUSING

Rarely, it might be necessary to access the internal circuit board on the receiver to adjust settings or change the radio channel.

To remove the CAN-6 receiver from the housing, first remove power from the CAN-6 receiver by turning off the master disconnect. Remove the connectors from the bottom of the receiver by squeezing in the release tabs on both sides of the connector. The bottom connector plate with the internal circuit board is removed by inserting a flat screwdriver into the top slots for the two side release tabs and giving a gentle twist. After releasing both sides one at a time, wiggle the circuit board from the housing side to side. Once the circuit board is free of the housing, disconnect the external antenna lead from the connector on the circuit board.

*NOTE: Use caution when removing the board from the housing, as the board can release suddenly while pulling it out of the housing. If enough force is being applied, the external antenna lead can be pulled off the board, causing damage.*

After making the necessary setting adjustments using the dip switches, re-install the bottom connector plate with the internal circuit board by first reconnecting the external antenna lead to the connector on the circuit board. Then slide the board and connector plate into the housing and press firmly to fully seat the bottom connector plate onto the housing.

### 3.5 PIN OUT DIAGRAM AND DEFINITIONS

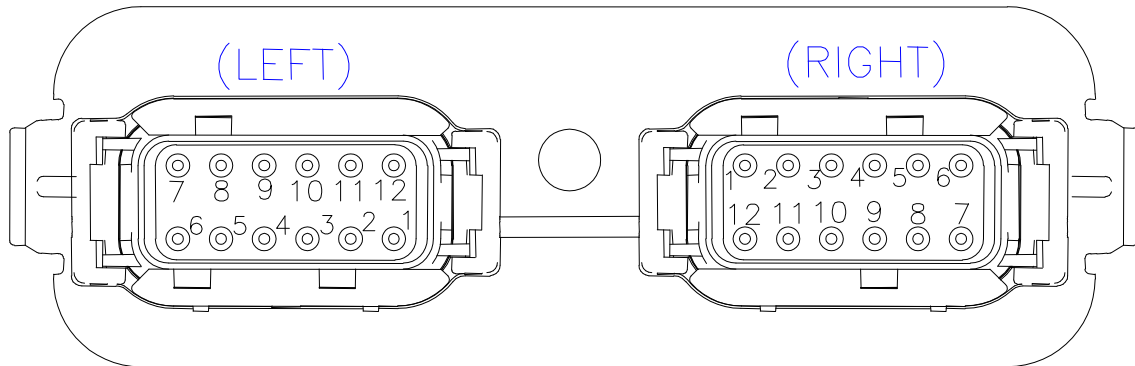

**Figure 06: Pin out diagram**

LEFT CONNECTOR CONNECTION DIAGRAM		
PIN	FUNCTION	DESCRIPTION
5	Output 1	Digital Output 1
8	Output 2	Digital Output 2
4	Output 3	Digital Output 3
9	Output 4	Digital Output 4
10	Output 5	Digital Output 5
3	Output 6	Digital Output 6
11	Output 7	Digital Output 7
12	Output 8	Reserved as radio E-stop
7	+VBatt	+12 to 24 VDC Power
6	-VBatt	Common
1	CANL	CAN Low
2	CANH	CAN High

RIGHT CONNECTOR CONNECTION DIAGRAM		
PIN	FUNCTION	DESCRIPTION
6	Output 9	Analog Output 1 (0-10VDC)
5	Output 10	Analog Output 2 (0-10VDC)
3	Output 11	Analog Output 3 (0-10VDC)
4	Output 12	Analog Output 4 (0-10VDC)
10	Output 13	Analog Output 5 (0-10VDC)
11	Output 14	Analog Output 6 (0-10VDC)
2	Output 15	Analog Output 7 (0-10VDC)
9	Output 16	Analog Output 8 (0-10VDC)
7	CANL	CAN Low
8	CANH	CAN High
1	+VBatt	+12 to 24 VDC
12	-VBatt	Common

### **+Vbattery (Left Pin 7 and Right Pin 1)**

The CAN-6 is designed to work in any 12–24VDC nominal (9–36VDC max) powered equipment. The +Vbattery pins should be connected to the positive terminal of the machine power supply through an approved Emergency Stop device. Additionally, CAN-6 +Vbattery pins should be protected by a 30A fast blow fuse. All +Vbattery pins must be connected.

### **-Vbattery (Left Pin 6 and Right Pin 12)**

The -Vbattery connections must be made directly to the negative supply and not to chassis ground. All -Vbattery pins must be connected.

### **Machine Stop (Left Pin 12)**

In order to ensure maximum safety of the equipment controlled by the CAN-6, a Machine Stop output is provided. The output can supply a current of up to 2 Amps. In the event of an unsafe condition, such as loss of communications, the machine stop output will be enabled.

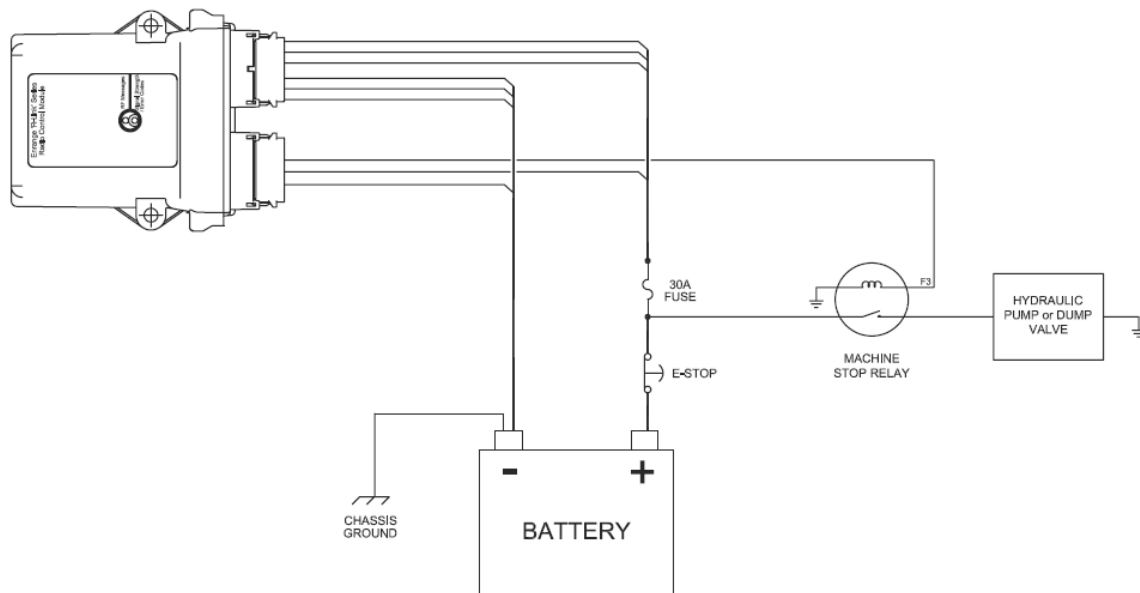

**Figure 07: CAN-6 Machine Stop Wiring**

Additionally, make sure that a Machine Stop is provided elsewhere on the equipment in which the CAN-6 is installed in order to comply with all applicable Machinery Directives.

### **Digital Outputs (Left Pins 3–5, 8–11, 12 reserved for Radio Machine Stop)**

The left connector has eight pins that are digital outputs with Pin 12 reserved for Machine Stop.

The digital voltage range is as follows: outputs less than 2V are a digital 0; inputs greater than 3V are a digital 1.

### **CAN (Left Pins 1 and 2, Right Pins 7 and 8)**

There is only one CAN-bus port on the CAN-6 but two pairs of pins for connection so the device can be wired in series with other CAN devices. The CAN-6 does not have an internal termination resistor, so if the device is the last device on that end of the CAN-bus, external termination is required.

### **Analog Outputs (Right Pins 2–6, 9–12)**

The right connector has 8 pins for analog outputs. These outputs deliver a voltage from 0 to 10 VDC.

### 3.6 CAN-6 RECEIVER BLOCK DIAGRAM

*NOTE: Connections are labeled by which side the connector is on the CAN-6 receiver. i.e. L1 is pin 1 on the left connector, R1 is pin 1 on the right connector, etc.*

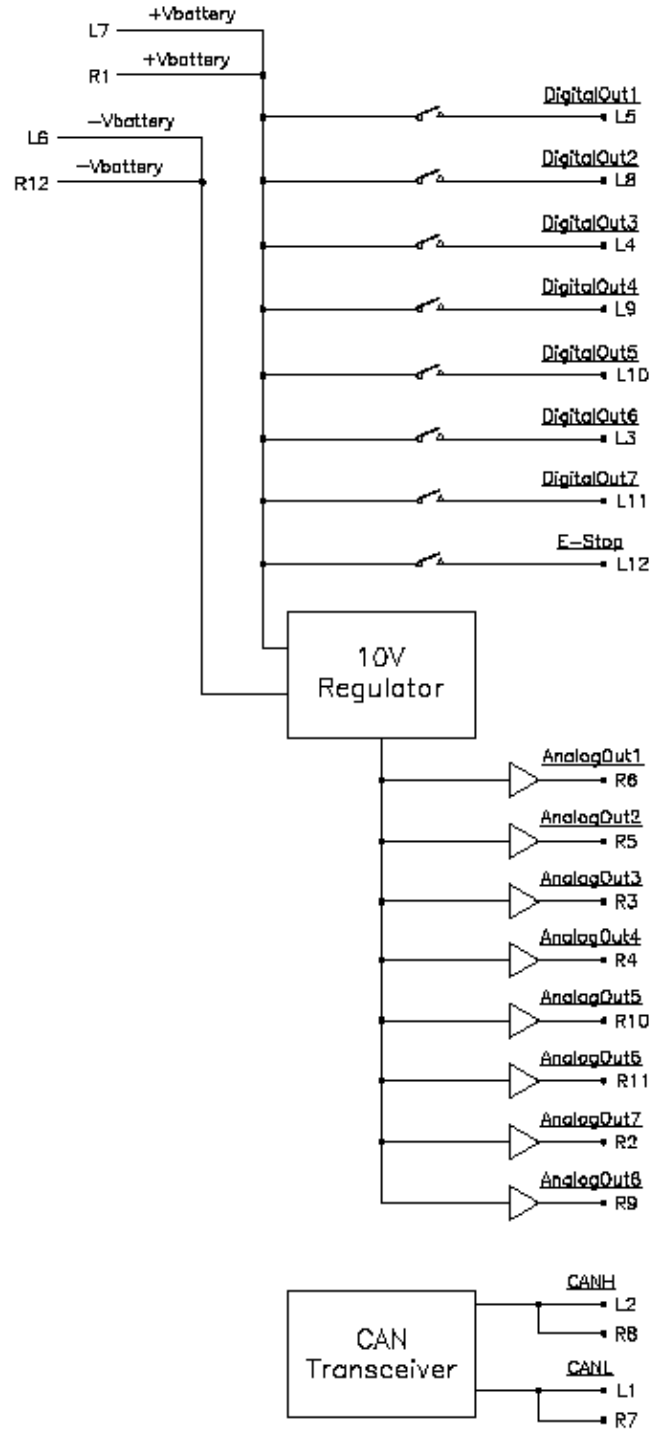

## 4.0 CONFIGURING THE CAN-6

The CAN-6 receiver will be pre-configured at the factory in most cases; the following sections are for reference for field adjustments.

*NOTE: Changing settings must be done with caution. Wrong settings can cause the equipment not to function and potentially cause damage to equipment or injury.*

### 4.1 SETTING ANTENNA TYPE

The antenna can be selected from internal to external on the CAN-6 module by utilizing SW8 on the Bank 1 dip switches.

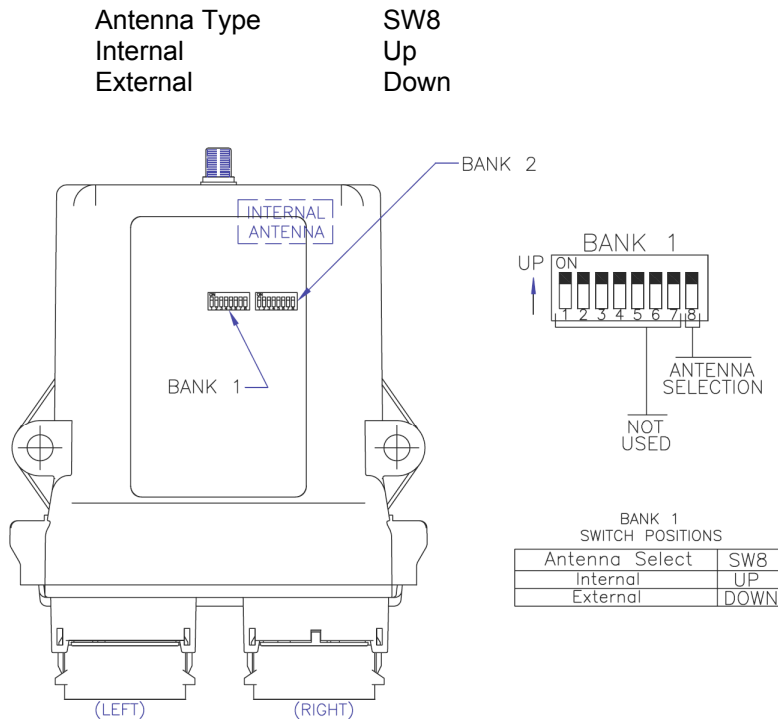

*NOTE: If the CAN-6 module is installed inside an enclosure, an external antenna must be used and the antenna type dip switch setting should be set to External.*

*NOTE: See Section 3.4 for instructions on how to remove the CAN-6 module from the module housing.*

### 4.2 REMAINING BANK 1 DIP SWITCH SETTINGS

The Bank 1 dip switches 1 through 7 are programmed at the factory for custom setting adjustments. Examples of settings that can be utilized are A, B, Both, RF Power, CAN Message Types, etc.

### 4.3 RECEIVER CHANNEL CONFIGURATION SETTINGS (DIP SWITCH BANK 2)

The channel can be set on the CAN-6 receiver via the Bank 2 dip switches. The following sections (Sections 4.3.1 through 4.3.3) show the channels or protocols available for each radio frequency option of the CAN-6.

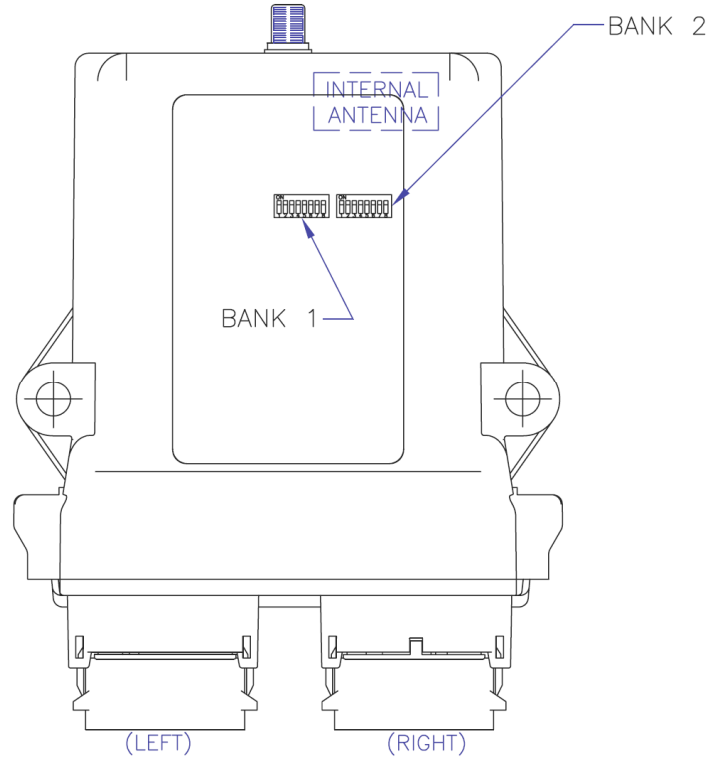

*NOTE: See Section 3.4 for instructions on how to remove the CAN-6 module from the module housing.*



### 4.3.1 Channel Dip Switch Settings for 900MHz Part 15



BANK 2  
SWITCH POSITIONS

CHANNEL	SW4	SW5	SW6	SW7	SW8
A (902.30 Mhz)	DOWN	DOWN	DOWN	UP	DOWN
B (904.10 Mhz)	UP	DOWN	DOWN	UP	DOWN
C (904.30 Mhz)	DOWN	UP	DOWN	UP	DOWN
D (905.10 Mhz)	UP	UP	DOWN	UP	DOWN
E (905.50 Mhz)	DOWN	DOWN	UP	UP	DOWN
F (905.70 Mhz)	UP	DOWN	UP	UP	DOWN
G (906.60 Mhz)	DOWN	UP	UP	UP	DOWN
H (908.70 Mhz)	UP	UP	UP	UP	DOWN
I (908.90 Mhz)	DOWN	DOWN	DOWN	DOWN	UP
J (909.10 Mhz)	UP	DOWN	DOWN	DOWN	UP
K (910.10 Mhz)	DOWN	UP	DOWN	DOWN	UP
L (910.70 Mhz)	UP	UP	DOWN	DOWN	UP
M (911.00 Mhz)	DOWN	DOWN	UP	DOWN	UP
N (911.20 Mhz)	UP	DOWN	UP	DOWN	UP
O (912.00 Mhz)	DOWN	UP	UP	DOWN	UP
P (914.20 Mhz)	UP	UP	UP	DOWN	UP
Q (914.40 Mhz)	DOWN	DOWN	DOWN	UP	UP
R (914.60 Mhz)	UP	DOWN	DOWN	UP	UP
S (914.80 Mhz)	DOWN	UP	DOWN	UP	UP
T (915.80 Mhz)	UP	UP	DOWN	UP	UP
U (917.40 Mhz)	DOWN	DOWN	UP	UP	UP
V (923.20 Mhz)	UP	DOWN	UP	UP	UP
W (927.00 Mhz)	DOWN	UP	UP	UP	UP
X (927.30 Mhz)	UP	UP	UP	UP	UP

900MHz

### 4.3.2 Channel Dip Switch Settings for 433MHz Part 15

BANK 2  
SWITCH POSITIONS

CHANNEL	SW1	SW2	SW3	SW4	SW5
1 (433.000 Mhz)	DOWN	DOWN	DOWN	DOWN	DOWN
2 (433.050 Mhz)	DOWN	DOWN	DOWN	DOWN	UP
3 (433.100 Mhz)	DOWN	DOWN	DOWN	UP	DOWN
4 (433.150 Mhz)	DOWN	DOWN	DOWN	UP	UP
5 (433.200 Mhz)	DOWN	DOWN	UP	DOWN	DOWN
6 (433.250 Mhz)	DOWN	DOWN	UP	DOWN	UP
7 (433.300 Mhz)	DOWN	DOWN	UP	UP	DOWN
8 (433.350 Mhz)	DOWN	DOWN	UP	UP	UP
9 (433.400 Mhz)	DOWN	UP	DOWN	DOWN	DOWN
10 (433.450 Mhz)	DOWN	UP	DOWN	DOWN	UP
11 (433.500 Mhz)	DOWN	UP	DOWN	UP	DOWN
12 (433.550 Mhz)	DOWN	UP	DOWN	UP	UP
13 (433.600 Mhz)	DOWN	UP	UP	DOWN	DOWN
14 (433.650 Mhz)	DOWN	UP	UP	DOWN	UP
15 (433.700 Mhz)	DOWN	UP	UP	UP	DOWN
16 (433.750 Mhz)	DOWN	UP	UP	UP	UP
17 (433.800 Mhz)	UP	DOWN	DOWN	DOWN	DOWN
18 (433.850 Mhz)	UP	DOWN	DOWN	DOWN	UP
19 (433.900 Mhz)	UP	DOWN	DOWN	UP	DOWN
20 (433.950 Mhz)	UP	DOWN	DOWN	UP	UP
21 (434.000 Mhz)	UP	DOWN	UP	DOWN	DOWN
22 (434.050 Mhz)	UP	DOWN	UP	DOWN	UP
23 (434.100 Mhz)	UP	DOWN	UP	UP	DOWN
24 (434.150 Mhz)	UP	DOWN	UP	UP	UP
25 (434.200 Mhz)	UP	UP	DOWN	DOWN	DOWN
26 (434.250 Mhz)	UP	UP	DOWN	DOWN	UP
27 (434.300 Mhz)	UP	UP	DOWN	UP	DOWN
28 (434.350 Mhz)	UP	UP	DOWN	UP	UP
29 (434.400 Mhz)	UP	UP	UP	DOWN	DOWN
30 (434.450 Mhz)	UP	UP	UP	DOWN	UP
31 (434.500 Mhz)	UP	UP	UP	UP	DOWN
32 (434.550 Mhz)	UP	UP	UP	UP	UP

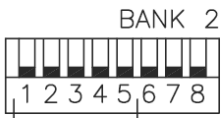

433MHz

### 4.3.3 Channel Dip Switch Settings for 2.4GHz @ 50mW and 125mW

BANK 2  
SWITCH POSITIONS

CHANNEL	SW4	SW5	SW6	SW7	SW8
1	DOWN	DOWN	DOWN	DOWN	DOWN
2	UP	DOWN	DOWN	DOWN	DOWN
3	DOWN	UP	DOWN	DOWN	DOWN
4	UP	UP	DOWN	DOWN	DOWN
5	DOWN	DOWN	UP	DOWN	DOWN
6	UP	DOWN	UP	DOWN	DOWN
7	DOWN	UP	UP	DOWN	DOWN
8	UP	UP	UP	DOWN	DOWN
9	DOWN	DOWN	DOWN	UP	DOWN
10	UP	DOWN	DOWN	UP	DOWN
11	DOWN	UP	DOWN	UP	DOWN
12	UP	UP	DOWN	UP	DOWN
13	DOWN	DOWN	UP	UP	DOWN
14	UP	DOWN	UP	UP	DOWN
15	DOWN	UP	UP	UP	DOWN
16	UP	UP	UP	UP	DOWN
17	DOWN	DOWN	DOWN	DOWN	UP
18	UP	DOWN	DOWN	DOWN	UP
19	DOWN	UP	DOWN	DOWN	UP
20	UP	UP	DOWN	DOWN	UP
21	DOWN	DOWN	UP	DOWN	UP
22	UP	DOWN	UP	DOWN	UP
23	DOWN	UP	UP	DOWN	UP
24	UP	UP	UP	DOWN	UP
25	DOWN	DOWN	DOWN	UP	UP
26	UP	DOWN	DOWN	UP	UP
27	DOWN	UP	DOWN	UP	UP
28	UP	UP	DOWN	UP	UP
29	DOWN	DOWN	UP	UP	UP
30	UP	DOWN	UP	UP	UP
31	DOWN	UP	UP	UP	UP
32	UP	UP	UP	UP	UP



2.4GHz FHSS

#### 4.4 FCC STATEMENTS

**Compliance Statement (Part 15.19)**

This device complies with Part 15 of FCC rules.

Operation is subject to the following two conditions:

1. This device may not cause harmful interference, and
2. This device must accept any interference received, including interference that may cause undesired operation.

**Warning (Part 15.21)**

Changes or modifications not expressly approved by the party responsible for compliance should void the user's authority to operate the equipment.

This portable transmitter with its antenna complies with FCC's RF exposure limits for general population/uncontrolled exposure.

## 5.0 NORMAL OPERATION

During normal operation the CAN-6 receiver will receive commands from the transmitter and convert them to output or CAN signals. During these operations, the operator can verify that the receiver is online and functioning by interpreting the status LED light pairs on the front of the CAN-6 receiver. If there are errors during operation, the LED lights can help troubleshoot the problem.

### 5.1 INITIALIZATION

During startup of the CAN-6 module after power is applied, the signal strength/error code LED will illuminate to provide initialization status.

Solid Green = Initialization ok, no errors present

Solid Red = Start up initialization error

After initialization is complete, the LED will then illuminate the signal strength and error code status as part of the normal operation.

### 5.2 NORMAL OPERATION

During normal operation of the receiver, the receiver will receive commands from the transmitter and convert them into outputs or CAN messages. During the operations, the receiver will communicate its status via LEDs.

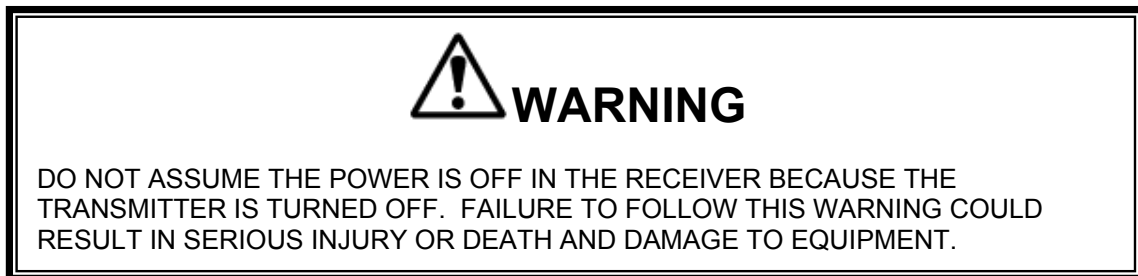

### 5.3 LED STATUS INDICATION

The CAN-6 has two LEDs for indicating the CAN-6 status at a glance during normal operation. The bottom LED indicates the CAN-6's signal strength/error codes, while the top LED indicates sending or receiving of messages.

#### 5.3.1 RF Messages LED (Top LED on CAN-6 Faceplate)

Green Slow Blinks - Transmitter is offline (watchdog indicator)

Green Fast Blinks - Each blink is a valid RF message

Red Blinks - Internal boot-up sequence

Red Solid - Error occurred, refer to Error Code LED's blink code

### 5.3.2 Signal Strength/Error Code LED (Bottom LED on CAN-6 Faceplate)

Solid Green = Good RF signal strength to transmitter

Solid Red = Poor RF signal strength to transmitter

Blinking Red = Error (code is picked up from number of blinks)

Red 2 Blinks - Commanded Power Down

Red 3 Blinks - RF Data Timeout

Red 4 Blinks - CANbus Timeout

Refer to Section 6.0 for the troubleshooting table to interpret error codes.

*NOTE: SIGNAL STRENGTH/ERROR CODE LED only illuminates green when the receiver is online with the transmitter. The SIGNAL STRENGTH/ERROR CODE LED will not illuminate green after the transmitter goes offline from the receiver. This can occur when the transmitter powers down from inactivity or goes out of range. The START toggle on the transmitter must be toggled to bring the transmitter back online with the receiver.*

## 6.0 TROUBLESHOOTING

### 6.1 TROUBLESHOOTING TABLE

<b>Problems</b>	<b>Possible Reasons</b>	<b>Suggestions</b>
<b>Receiver will not turn on</b>	Supplied voltage is out of the acceptable range	Ensure the voltage is with 12–24VDC nominal (9–36VDC max).
	Internal fuse has blown	Contact the factory.
<b>Receiver will not respond to the Transmitter</b>	Incorrect system RF channel	Make sure the receiver and transmitter unit are both set to the same RF channel.
	Incorrect system access code	Make sure the receiver and transmitter both have the same access code.
	System out of range	Make sure that the startup procedure is initiated within 300 feet from the receiver location. If equipped with the Signal Strength Indicator, make sure the level is greater than 0%.
	The antenna on the receiver is missing, damaged, or improperly installed	Inspect the antenna on the receiver for damage and try to place the antenna in a location that is visible when operating the equipment at all times.
	The antenna setting on the receiver is incorrect	Make sure the antenna setting (internal or external) is for the antenna type being used.
<b>CAN messages are not being received by the receiver</b>	The CAN message being sent is not supported	Use the supported messages OR contact your supplier to inquire about a software update.
	Termination resistor is not present or it has an incorrect value	Install termination resistor and verify correct value (120 Ohms at each end of the bus).
	Incorrect baud rate	Ensure the correct baud rate is set by all devices on the bus.

<b>CAN messages transmitted by the receiver are not being received</b>	Incorrect source address	Make sure that the source address of the receiver is set correctly.
	The termination resistor is set incorrectly	Ensure the termination resistor is appropriately set.
	Incorrect baud rate	Ensure the correct baud rate is set by all devices on the bus.
<b>Outputs not functioning</b>	Faulty Wiring	Check all wires for loose or damaged connections.
	Output is shorted or opened	Check all wires and connections for damaged insulation.

**Table 1: Troubleshooting Table**



## **6.2 ASSEMBLY AND REPLACEMENT PARTS**

If your receiver ever needs repair, we always recommend that you have Magnetek perform the repair. If you need to refer to a parts list, refer to your receiver's drawing that was included in the shipment of your receiver. Please contact Magnetek's service department at 1.866.MAG.SERV for information regarding parts and service.