

# FLEX M

## *Pre-Engineered*

(Flex M-16, -24, -32)

---

## Modular Receiver

---



**MAGNETEK**  
E N R A N G E

Part Number: 198-00121-R3  
May 2011

© 2011 Magnetek Material Handling

## Your New Radio Receiver

Thank you for your purchase of Magnetek's Enrange® brand Flex M Radio Remote Equipment Control. Magnetek has set a whole new standard in radio-remote performance, dependability, and value with this line of modular receivers.

If your product ever needs modification or service, please contact one of our representatives at the following locations:

### **U.S. Service Information**

For questions regarding service or technical information contact:

**1.866.MAG.SERV**  
**(1.866.624.7378).**

Magnetek Enrange  
#5 Four Coins Drive  
Canonsburg, PA 15317

**Telephone:** 1.800.288.8178

**Website:** [www.magnetekmh.com](http://www.magnetekmh.com)  
**e-mail:** [info@magnetekmh.com](mailto:info@magnetekmh.com)

#### **Fax Numbers:**

*Main:* 800.298.3503  
*Sales:* 262.783.3510  
*Service:* 262.783.3508

### **Canada Service Information:**

4090B Sladeview Crescent  
Mississauga, Ontario  
L5L 5Y5 Canada  
Phone: 1.800.792.7253  
Fax: 1.905.828.5707  
416.424.7617 (24/7 Service pager)

©2011 MAGNETEK

All rights reserved. This notice applies to all copyrighted materials included with this product, including, but not limited to, this manual and software embodied within the product. This manual is intended for the sole use of the person(s) to whom it was provided, and any unauthorized distribution of the manual or dispersal of its contents is strictly forbidden. This manual may not be reproduced in whole or in part by any means whatsoever without the expressed written permission of MAGNETEK.

## **TABLE OF CONTENTS**

1.0: CRITICAL INSTALLATION CONSIDERATIONS .....	3
1.1 GENERAL .....	3
1.2 PERSONS AUTHORIZED TO OPERATE RADIO CONTROLLED EQUIPMENT .....	3
1.3 SAFETY INFORMATION & RECOMMENDED TRAINING FOR OPERATORS .....	4
1.4 PRE-OPERATION TEST .....	5
2.0 FLEX M RECEIVER INSTALLATION .....	6
2.1 PRE-INSTALLATION .....	6
2.2 MECHANICAL DRAWINGS .....	7
2.3 INSTALLATION .....	8
2.4 REMOVAL .....	9
3.0 NORMAL OPERATION .....	10
3.1 POWER SUPPLY MODULE .....	10
3.2 RF/CPU MODULE .....	10
3.3 RELAY MODULE(S) .....	10
4.0 FLEX MODULE TYPES .....	11
4.1 FLEX RF/CPU MODULE .....	11
4.1.1 Bank 1 Dipswitch Setting Definitions .....	11
4.1.1.1 Bank 1 Switches 1 through 5 – Relay configuration program select .....	11
4.1.1.2 Bank 1 Switch 6 – Invert A/B Select Outputs (Normally OFF) .....	11
4.1.1.3 Bank 1 Switch 7 – Auxiliary Relay Output Select (Normally OFF) .....	12
4.1.1.4 Bank 1 Switch 8 – Disable Tandem (A/B both) Select (Normally OFF) .....	12
4.1.2 Bank 2 Dipswitch Setting Definitions .....	12
4.1.2.1 Bank 2 Switch 1 – AUX 1/2 Output Configuration (Normally ON) .....	12
4.1.2.2 Bank 2 Switch 2 – AUX 3/4 Output Configuration (Normally ON) .....	12
4.1.2.3 Bank 2 Switch 3 – AUX 5/6 Output Configuration (Normally ON) .....	13
4.1.2.4 Bank 2 Switches 4 thru 8 – Radio Frequency channel select .....	13
4.2 FLEX M RELAY MODULE .....	13
4.3 FLEX M 120VAC POWER MODULE .....	14
5.0 FLEX SYSTEMS – OVERVIEW, SETTINGS AND WIRING DIAGRAMS .....	16
5.1 FLEX M-16 SYSTEM OVERVIEW .....	16
5.1.1 Flex M 16 Relay Configuration Settings (Bank 1 on RF/CPU Module) .....	16
5.1.2 Flex M 16 Relay Configuration Descriptions .....	17
5.2 FLEX M-24 SYSTEM OVERVIEW .....	21
5.2.1 Flex M 24 Relay Configuration Settings (Bank 1 on RF/CPU Module) .....	21
5.2.2 Flex M 24 Relay Configuration Descriptions .....	22
5.3 FLEX M-32 SYSTEM OVERVIEW .....	23
5.3.1 Flex M 32 Relay Configuration Settings (Bank 1 on RF/CPU Module) .....	23
5.3.2 Flex M 32 Relay Configuration Descriptions .....	24
6.0 CHANNEL CONFIGURATION SETTINGS (BANK 2 ON RF/CPU MODULE) .....	27
6.1 FCC STATEMENTS .....	27
7.0 TROUBLESHOOTING .....	28
7.1 TROUBLESHOOTING TABLE .....	29
7.2 ASSEMBLY AND REPLACEMENT PARTS .....	31

## PRODUCT MANUAL SAFETY INFORMATION

Magnetek, Inc. (Magnetek) offers a broad range of radio remote control products, control products and adjustable frequency drives, and industrial braking systems for overhead material handling applications. This manual has been prepared by Magnetek to provide information and recommendations for the installation, use, operation and service of Magnetek's material handling products and systems (Magnetek Products). Anyone who uses, operates, maintains, services, installs or owns Magnetek Products should know, understand and follow our instructions and safety recommendations in this manual for Magnetek Products.

The recommendations in this manual do not take precedence over any of the following requirements relating to cranes, hoists and lifting devices:

- Instructions, manuals, and safety warnings of the manufacturers of the equipment where the radio system is used,
- Plant safety rules and procedures of the employers and the owners of facilities where the Magnetek Products are being used,
- Regulations issued by the Occupational Health and Safety Administration (OSHA),
- Applicable local, state or federal codes, ordinances, standards and requirements, or
- Safety standards and practices for the overhead material handling industry.

This manual does not include or address the specific instructions and safety warnings of these manufacturers or any of the other requirements listed above. It is the responsibility of the owners, users and operators of the Magnetek Products to know, understand and follow all of these requirements. It is the responsibility of the owner of the Magnetek Products to make its employees aware of all of the above listed requirements and to make certain that all operators are properly trained. **No one should use Magnetek Products prior to becoming familiar with and being trained in these requirements.**

### WARRANTY INFORMATION

FOR INFORMATION ON MAGNETEK'S PRODUCT WARRANTIES BY PRODUCT TYPE, PLEASE VISIT [WWW.MAGNETEKMH.COM](http://WWW.MAGNETEKMH.COM).

## **WARNINGS and CAUTIONS**

Throughout this document WARNING and CAUTION statements have been deliberately placed to highlight items critical to the protection of personnel and equipment.

**WARNING – A warning highlights an essential operating or maintenance procedure, practice, etc. which if not strictly observed, could result in injury or death of personnel, or long term physical hazards. Warnings are highlighted as shown below:**



**CAUTION – A caution highlights an essential operating or maintenance procedure, practice, etc. which if not strictly observed, could result in damage to, or destruction of equipment, or loss of functional effectiveness. Cautions are highlighted as shown below:**



**WARNINGS and CAUTIONS SHOULD NEVER BE DISREGARDED.**

The safety rules in this section are not intended to replace any rules or regulations of any applicable local, state, or federal governing organizations. Always follow your local lockout and tagout procedure when maintaining any radio equipment. The following information is intended to be used in conjunction with other rules or regulations already in existence. It is important to read all of the safety information contained in this section before installing or operating the Radio Control System.

## 1.0: CRITICAL INSTALLATION CONSIDERATIONS



### WARNING

PRIOR TO INSTALLATION AND OPERATION OF THIS EQUIPMENT, READ AND DEVELOP AN UNDERSTANDING OF THE CONTENTS OF THIS MANUAL AND THE OPERATION MANUAL OF THE EQUIPMENT OR DEVICE TO WHICH THIS EQUIPMENT WILL BE INTERFACED. FAILURE TO FOLLOW THIS WARNING COULD RESULT IN SERIOUS INJURY OR DEATH AND DAMAGE TO EQUIPMENT.

ALL EQUIPMENT MUST HAVE A MAINLINE CONTACTOR INSTALLED AND ALL TRACKED CRANES, HOISTS, LIFTING DEVICES AND SIMILAR EQUIPMENT MUST HAVE A BRAKE INSTALLED. FAILURE TO FOLLOW THIS WARNING COULD RESULT IN SERIOUS INJURY OR DEATH AND DAMAGE TO EQUIPMENT.

AN AUDIBLE AND/OR VISUAL WARNING MEANS MUST BE PROVIDED ON ALL REMOTE CONTROLLED EQUIPMENT AS REQUIRED BY CODE, REGULATION, OR INDUSTRY STANDARD. THESE AUDIBLE AND/OR VISUAL WARNING DEVICES MUST MEET ALL GOVERNMENTAL REQUIREMENTS. FAILURE TO FOLLOW THIS WARNING COULD RESULT IN SERIOUS INJURY OR DEATH AND DAMAGE TO EQUIPMENT.

FOLLOW YOUR LOCAL LOCKOUT TAGOUT PROCEDURE BEFORE MAINTAINING ANY REMOTE CONTROLLED EQUIPMENT. ALWAYS REMOVE ALL ELECTRICAL POWER FROM THE CRANE, HOIST, LIFTING DEVICE OR SIMILAR EQUIPMENT BEFORE ATTEMPTING ANY INSTALLATION PROCEDURES. DE-ENERGIZE AND TAGOUT ALL SOURCES OF ELECTRICAL POWER BEFORE TOUCH-TESTING ANY EQUIPMENT. FAILURE TO FOLLOW THIS WARNING COULD RESULT IN SERIOUS INJURY OR DEATH AND DAMAGE TO EQUIPMENT.

THE DIRECT OUTPUTS OF THIS PRODUCT ARE NOT DESIGNED TO INTERFACE DIRECTLY TO TWO STATE SAFETY CRITICAL MAINTAINED FUNCTIONS, I.E., MAGNETS, VACUUM LIFTS, PUMPS, EMERGENCY EQUIPMENT, ETC. A MECHANICALLY LOCKING INTERMEDIATE RELAY SYSTEM WITH SEPARATE POWER CONSIDERATIONS MUST BE PROVIDED. FAILURE TO FOLLOW THIS WARNING COULD RESULT IN SERIOUS INJURY OR DEATH OR DAMAGE TO EQUIPMENT.

### 1.1 GENERAL

Radio controlled material handling equipment operates in several directions. Cranes, hoists, lifting devices and other material handling equipment can be large, and operate at high speeds. Quite frequently, the equipment is operated in areas where people are working in close proximity to the material handling equipment. **The operator must exercise extreme caution at all times.** Workers must constantly be alert to avoid accidents. The following recommendations have been included to indicate how careful and thoughtful actions may prevent injuries, damage to equipment, or even save a life.

### 1.2 PERSONS AUTHORIZED TO OPERATE RADIO CONTROLLED EQUIPMENT

Only properly trained persons designated by management should be permitted to operate radio controlled equipment.

Radio controlled cranes, hoists, lifting devices and other material handling equipment should not be operated by any person who cannot read or understand signs, notices and operating instructions that pertain to the equipment.

Radio controlled equipment should not be operated by any person with insufficient eyesight or hearing or by any person who may be suffering from a disorder or illness, is taking any medication that may cause loss of equipment control, or is under the influence of alcohol or drugs.

### 1.3 SAFETY INFORMATION & RECOMMENDED TRAINING FOR OPERATORS

Anyone being trained to operate radio controlled equipment should possess as a minimum the following knowledge and skills before using the radio controlled equipment.

The operator should:

- have knowledge of hazards pertaining to equipment operation
- have knowledge of safety rules for radio controlled equipment
- have the ability to judge distance of moving objects
- know how to properly test prior to operation
- be trained in the safe operation of the radio receiver as it pertains to the crane, hoist, lifting device or other material handling equipment being operated
- have knowledge of the use of equipment warning lights and alarms
- have knowledge of the proper storage space for a radio control receiver when not in use
- be trained in transferring a radio control receiver to another person
- be trained how and when to report unsafe or unusual operating conditions
- test the receiver emergency stop and all warning devices prior to operation; testing should be done on each shift, without a load
- be thoroughly trained and knowledgeable in proper and safe operation of the crane, hoist, lifting device, or other material handling equipment that utilizes the radio control
- know how to keep the operator and other people clear of lifted loads and to avoid “pinch” points
- continuously watch and monitor status of lifted loads
- know and follow cable and hook inspection procedures
- know and follow the local lockout and tagout procedures when servicing radio controlled equipment
- know and follow all applicable operating and maintenance manuals, safety procedures, regulatory requirements, and industry standards and codes

The operator shall not:

- lift or move more than the rated load
- operate the material handling equipment if the direction of travel or function engaged does not agree with what is indicated on the controller
- use the crane, hoist or lifting device to lift, support or transport people
- lift or carry any loads over people
- operate the crane, hoist or lifting device unless all persons, including the operator, are and remain clear of the supported load and any potential pinch points
- operate a crane, hoist or lifting device when the device is not centered over the load

- operate a crane, hoist or lifting device if the chain or wire rope is not seated properly in the sprockets, drum or sheave
- operate any damaged or malfunctioning crane, hoist, lifting device or other material handling equipment
- change any settings or controls without authorization and proper training
- remove or obscure any warning or safety labels or tags
- leave any load unattended while lifted
- leave power on the radio controlled equipment when the equipment is not in operation
- operate any material handling equipment using a damaged controller because the unit may be unsafe
- operate manual motions with other than manual power
- operate radio controlled equipment when low battery indicator is on



## **WARNING**

THE OPERATOR SHOULD NOT ATTEMPT TO REPAIR ANY RADIO CONTROLLER. IF ANY PRODUCT PERFORMANCE OR SAFETY CONCERNS ARE OBSERVED, THE EQUIPMENT SHOULD IMMEDIATELY BE TAKEN OUT OF SERVICE AND BE REPORTED TO THE SUPERVISOR. DAMAGED AND INOPERABLE RADIO CONTROLLER EQUIPMENT SHOULD BE RETURNED TO MAGNETEK FOR EVALUATION AND REPAIR. FAILURE TO FOLLOW THIS WARNING COULD RESULT IN SERIOUS INJURY OR DEATH AND DAMAGE TO EQUIPMENT.

### **1.4 PRE-OPERATION TEST**

At the start of each work shift, or when a new operator takes control of the crane, operators should do, as a minimum, the following steps before making lifts with any crane or hoist:

Test all warning devices.

**Test all direction and speed controls.**

Test the receiver emergency stop.



## 2.0 FLEX M RECEIVER INSTALLATION



### **WARNING**

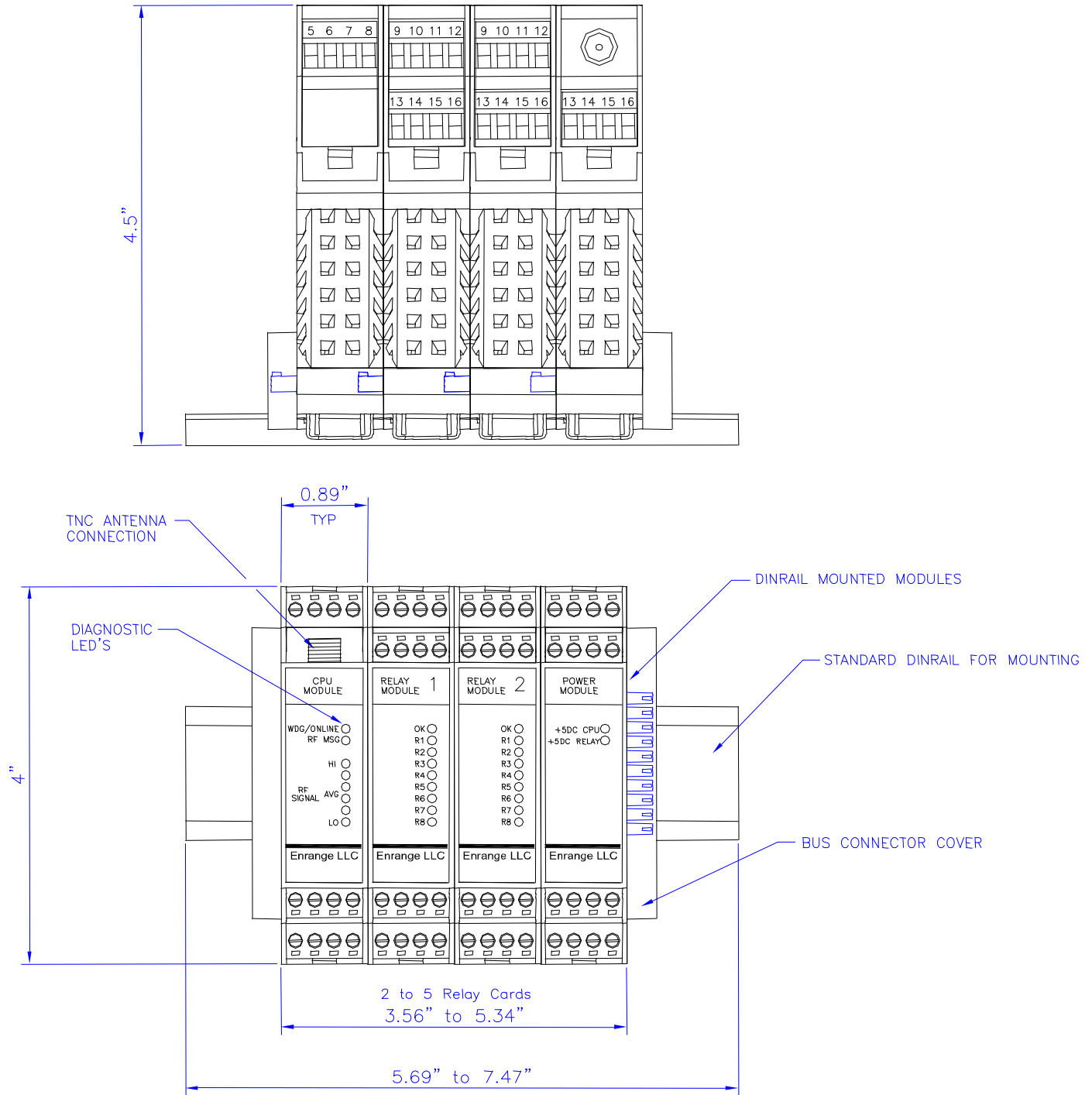
BEFORE OPERATING THE RECEIVER FAMILIARIZE YOURSELF WITH ALL SAFETY INFORMATION IN THIS MANUAL, APPROPRIATE MANUAL SUPPLEMENTS AND ANY OTHER LOCAL, STATE, OR FEDERAL RULES OR REGULATIONS ALREADY IN EXISTENCE. FAILURE TO FOLLOW THIS WARNING COULD RESULT IN SERIOUS INJURY OR DEATH AND DAMAGE TO EQUIPMENT.

### 2.1 PRE-INSTALLATION

1. The transmitter and receiver access code and channel must match before the system will communicate.
2. Be aware of other radio channels in the surrounding area - set your system to a unique channel.
3. Make sure that your equipment is working properly in manual mode prior to system installation.
4. Make sure the power to the receiver is the correct voltage.
5. Disconnect equipment power prior to system installation.

## 2.2 MECHANICAL DRAWINGS

### TYPICAL MECHANICAL LAYOUTS



**Figure 1: Mechanical Layout**

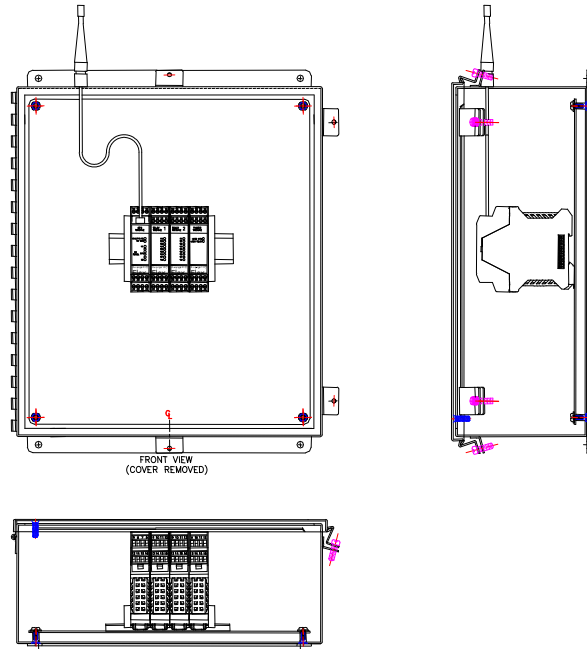


Figure 2: Example of Flex M Mounted in an Enclosure

## 2.3 INSTALLATION

1. **Be sure to mount the receiver antenna in direct line-of-sight of the operator and free from all obstructions.**
2. Do not mount the receiver near high levels of electric noise, such as an unshielded variable frequency drive, as it may cause minor interference. When mounting the Flex M near unshielded variable frequency drive, **Magnetek typically recommends that the Flex M and all antenna cable routing be mounted a minimum of 24 inches from all unshielded variable frequency drives and cables.**
3. Allow adequate room for mounting the receiver. Make sure to allow a minimum of 5" between connector and nearest surface to allow for cable harness connections.
4. For best reception and to help protect connectors from moisture and water damage, mount the receiver in an upright position. Mount with back flush against a flat surface to protect vents from spray.
5. If obstructions cannot be cleared, or the unit must be mounted inside a metal enclosure, the remote antenna should be used (see Figure 2).
6. Do not enclose the antenna in steel. For best reception, keep all metal objects away from the antenna. **Consult the factory for more information regarding your application.**
7. The supply power to the Flex M system must have a master disconnect and should be fused.
8. The Flex M modules are installed on a 35mm Din rail. To install the individual modules on the Din rail, hook the bottom of the module on the Din rail and swing the top of the module to the rail until a click is heard or felt.
9. After the modules are placed on the rail, they are slid together so they nest together. Rail clamps are suggested to prevent the module bundle from sliding freely on the rail.
10. **Modules MUST be installed so that the RF/CPU module is on the left end of the rail and the power supply module is on the right end of the rail.**

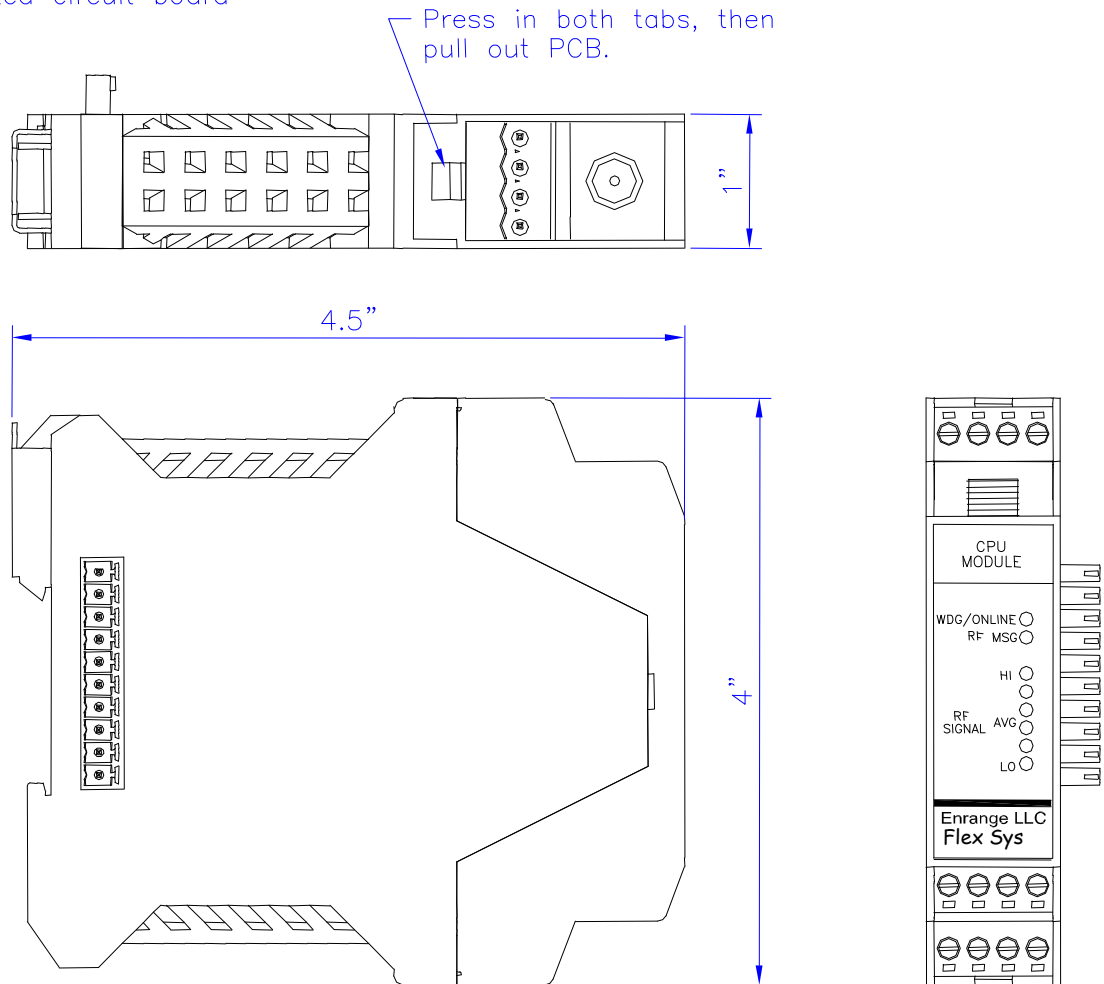
*NOTE: Magnetek strongly recommends the use of external fuses and circuit disconnects for all Flex Modules. Consult factory for more information.*

## 2.4 REMOVAL

1. To remove modules from the rail for service, first ensure all power to the Flex M modules has been turned off and proper lockout/tagout procedures have been followed.
2. Remove one end rail clamp and un-nest the module that you wish to remove by separating it from the others on the rail.
3. Use a slotted screwdriver to lift the exposed metal tab/ring on the top of the module. Swing the module down away from the top tab/ring and unhook from the rail.
4. The PCB from any module can be removed from its housing by pressing in both tabs first (tabs are on the front and back sides of the housing) and then the top housing and PCB can be removed from the lower housing (see Figure 3 for details).

### Notes:

In order to set dip switches the top along with the printed circuit board need to be removed from the base enclosure. Press in the tabs as shown below to remove the printed circuit board



**Figure 3: PCB Removal**

### 3.0 NORMAL OPERATION

During the operation of the receiver, following the LED indicators will allow observation of the status of the Flex M receiver.

#### 3.1 POWER SUPPLY MODULE

When the Flex M system has power supplied, the two LEDs on the power supply module should be lit and solid.

- +5Vdc CPU – indicates that +5Vdc power is going to the CPU
- +5Vdc RELAY – indicates that +5Vdc power is going to the RELAY modules

#### 3.2 RF/CPU MODULE

When the Flex M system is supplying power to the RF/CPU module, there is a series of LEDs that will indicate the RF/CPU module's status.

WDG/ONLINE LED:

- Solid indicates RF communication with transmitter
- 1 Blink indicates normal operating WDG
- 2 Blinks indicates RF communication loss with transmitter
- 3 Blinks indicates read/write error to an attached Flex M module

RF MSG LED:

- Fast Blinks indicates radio frequency messages received (typical is 4 to 10 messages per second). This confirms communication between transmitter and receiver
- 3 Steady Blinks indicates read/write error to an attached Flex M module
- 4 Steady Blinks indicates an internal radio error

RF SIGNAL LED – measures the strength of the RF communication signal from the transmitter

#### 3.3 RELAY MODULE(S)

When the Flex M system is supplying power to the Relay module, there is an LED that indicates the power and communication status of the Relay module.

- OK LED – Solid indicates module communication with system is good
- 3 Blinks indicates read/write error to attached CPU

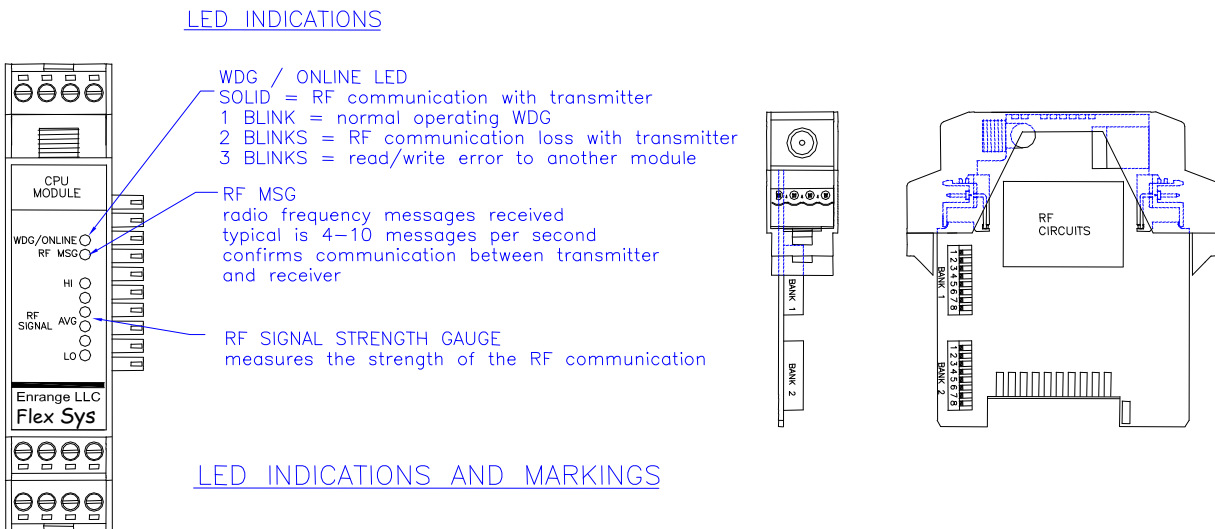
Additionally, there are eight LEDs labeled R1 through R8 on the Relay module. When the LED is on, this indicates that the relay is closed/activated.

## 4.0 FLEX MODULE TYPES

The Flex M system consists of an RF/CPU module, multiple relay modules and a power supply module.

### 4.1 FLEX RF/CPU MODULE

The Flex RF/CPU Module is the main module that receives radio signals from a paired transmitter and interprets those signals into the appropriate response from the attached I/O modules. There is one RF/CPU module in the Flex M System.



The dip switches are used to set the channel and to set relay output type. The dip switches can be accessed by removing the module from the rail (see Section 2.4 for details on how to remove the modules from the rail). After removing the RF/CPU module from the Din rail, press in the tabs to release the PCB from the housing (see Section 2.4 for details) and set the dip switches as necessary for the Flex M system utilized (Section 5.0 details switch settings for each Flex system). There are no wires to attach to the RF/CPU module aside from either an antenna or an RF Cable on the TNC antenna connection.

#### 4.1.1 Bank 1 Dipswitch Setting Definitions

The following describes the definitions and functions of the Bank 1 dipswitch block on the RF/CPU module:

##### 4.1.1.1 Bank 1 Switches 1 through 5 – Relay configuration program select

These switches can be set per Section 5.0 for the desired relay outputs for the system.

##### 4.1.1.2 Bank 1 Switch 6 – Invert A/B Select Outputs (Normally OFF)

Definition: This feature is only for custom crane relay configurations using A/B select relays.

Programming: Turning bank 1 dip switch position 6 ON (1) inverts the select function operation so that the relay outputs are now normally closed, so when selected, the output will be open.

#### **4.1.1.3 Bank 1 Switch 7 – Auxiliary Relay Output Select (Normally OFF)**

Definition: This feature is only for custom crane relay configurations that have outputs that can be configured as either A/B select or Aux 1/2.

Programming: Turning bank 1 dip switch position 7 OFF (0) sets the outputs to use Aux 1/2 logic. Turning bank 1 dip switch position 7 ON (1) sets the outputs to use A/B select logic.

#### **4.1.1.4 Bank 1 Switch 8 – Disable Tandem (A/B both) Select (Normally OFF)**

Definition: This feature is only for systems that use a tandem selector (or A/B select) logic. This setting is used to disable the tandem (or A/B Both) setting.

Programming: Turning bank 1 dipswitch position 8 OFF (0) enables tandem (or A/B Both) logic. Turning bank 1 dipswitch position 8 ON (1) disables tandem (or A/B Both) logic.

### **4.1.2 Bank 2 Dipswitch Setting Definitions**

The following describes the definitions and functions of the Bank 2 dipswitch block on the RF/CPU module:

#### **4.1.2.1 Bank 2 Switch 1 – AUX 1/2 Output Configuration (Normally ON)**

Definition: This feature sets the Aux 1/2 output relays to be either momentary or latched. When set for momentary outputs, each output will remain on as long as the corresponding button on the transmitter is held. When set for latched outputs, each output will turn on when the corresponding button on the transmitter is pushed, and will turn off when the corresponding button on the transmitter is pushed a second time. **The latching setting is not to be used for critical latching functions, such as magnets. For critical latching functions, an external mechanical latching relay should be used with the radio's outputs configured as momentary.**

Programming: Turning bank 2 dip switch position 1 OFF (0) sets the Aux 1/2 outputs to latched. Turning bank 2 dip switch position 1 ON (1) sets the Aux 1/2 outputs to momentary.

#### **4.1.2.2 Bank 2 Switch 2 – AUX 3/4 Output Configuration (Normally ON)**

Definition: This feature sets the Aux 3/4 output relays to be either momentary or latched. When set for momentary outputs, each output will remain on as long as the corresponding button on the transmitter is held. When set for latched outputs, each output will turn on when the corresponding button on the transmitter is pushed, and will turn off when the corresponding button on the transmitter is pushed a second time. **The latching setting is not to be used for critical latching functions, such as magnets. For critical latching functions, an external mechanical latching relay should be used with the radio's outputs configured as momentary.**

Programming: Turning bank 2 dip switch position 2 OFF (0) sets the Aux 3/4 outputs to latched. Turning bank 2 dip switch position 2 ON (1) sets the Aux 3/4 outputs to momentary.

#### 4.1.2.3 Bank 2 Switch 3 – AUX 5/6 Output Configuration (Normally ON)

Definition: This feature sets the Aux 5/6 output relays to be either momentary or latched. When set for momentary outputs, each output will remain on as long as the corresponding button on the transmitter is held. When set for latched outputs, each output will turn on when the corresponding button on the transmitter is pushed, and will turn off when the corresponding button on the transmitter is pushed a second time. **The latching setting is not to be used for critical latching functions, such as magnets. For critical latching functions, an external mechanical latching relay should be used with the radio's outputs configured as momentary.**

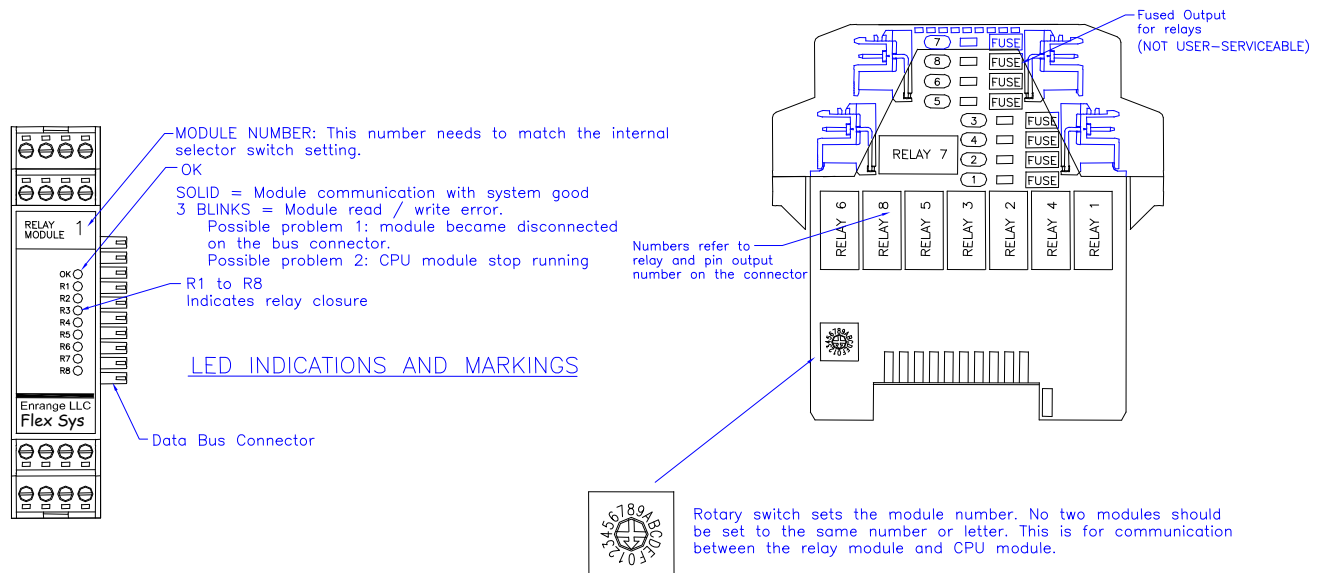
Programming: Turning bank 2 dip switch position 3 OFF (0) sets the Aux 5/6 outputs to latched. Turning bank 2 dip switch position 3 ON (1) sets the Aux 5/6 outputs to momentary.

#### 4.1.2.4 Bank 2 Switches 4 thru 8 – Radio Frequency channel select

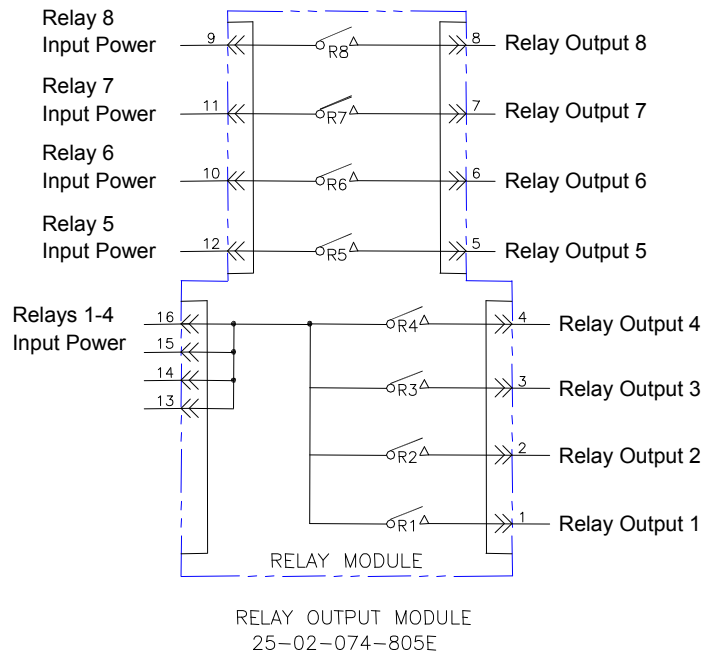
These switches can be set per section 6.0 for the desired operational radio channel frequency for the system.

### 4.2 FLEX M RELAY MODULE

The Flex M Relay module allows the control of high current power (up to 5A) for attached equipment through eight relay outputs. Four relays have a common power input and four relays have individually separate power inputs. There are typically 2 to 5 relay modules in Flex M systems where the relay module number is set by the rotary switch located on the lower left corner of the board.



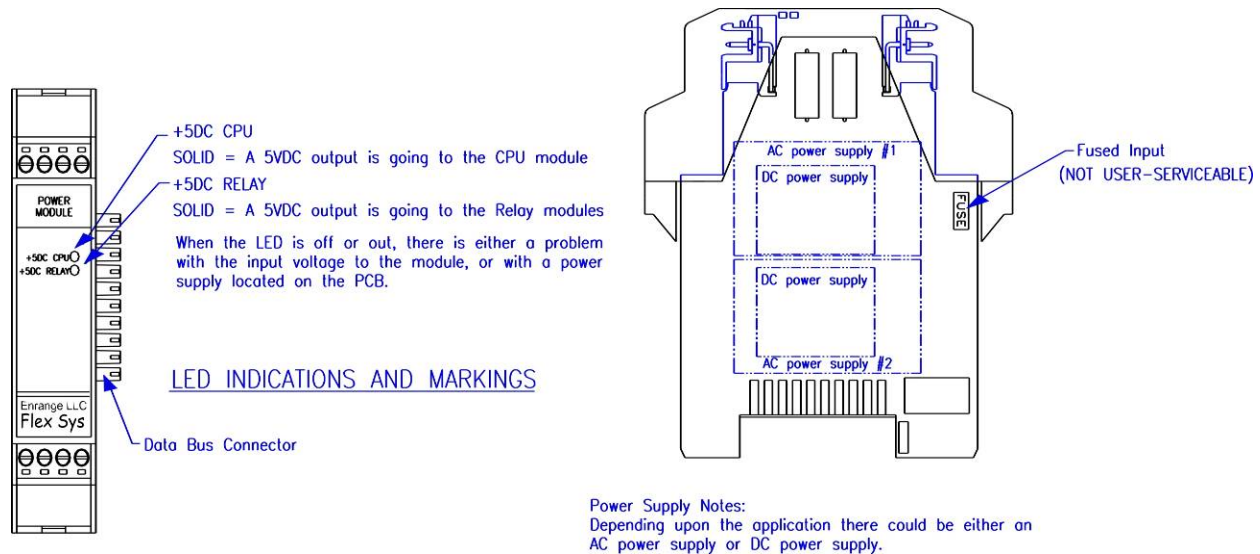


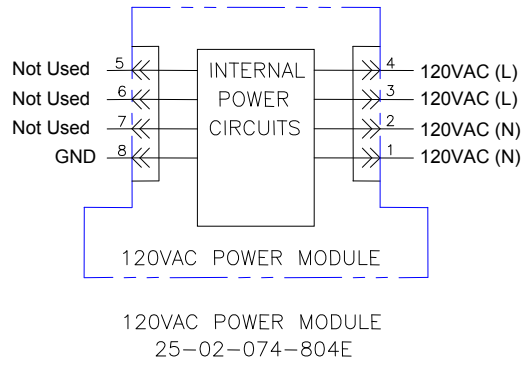


**Figure 4: Typical Relay Wiring**

### 4.3 FLEX M 120VAC POWER MODULE

The Flex M Power Module converts the 120VAC supply power to 5VDC power for all the attached Flex M modules. This power module has a maximum output supply current of 1000mA. There is one 120VAC Power Module in the Flex M system.





**Figure 5: Typical 120VAC Power Wiring**

**Notes:**

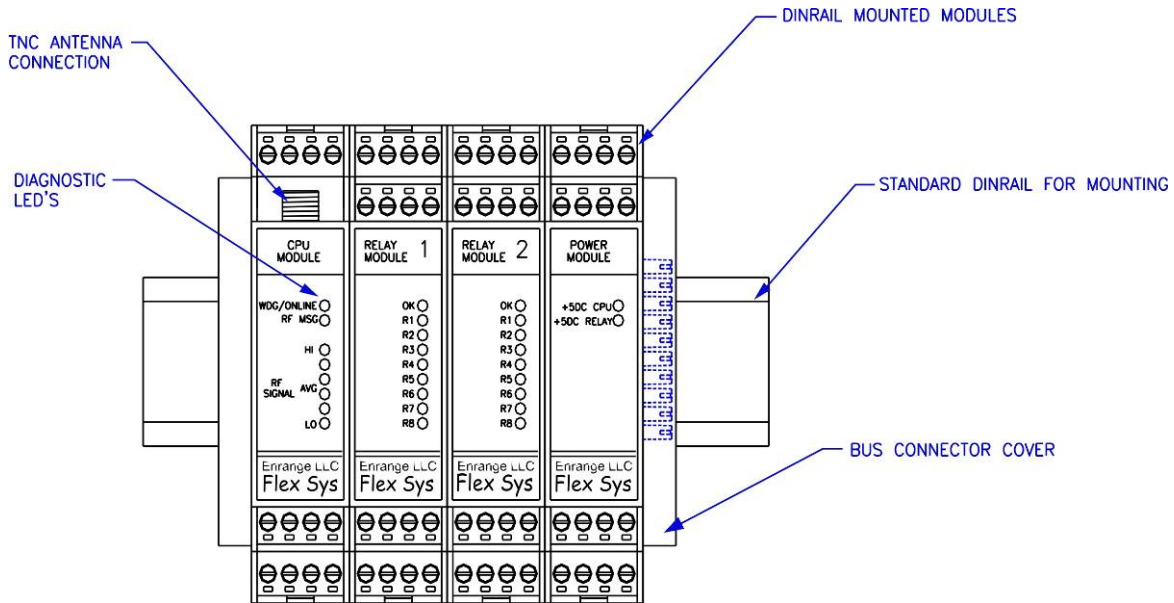
1. Although the power module has built-in protection, Magnetek strongly recommends the use of external fuses and circuit disconnects for all Flex Modules.
2. The built-in fuse is not user-serviceable but can be checked if troubleshooting. To check the fuse, remove the power module from the din rail as described in Section 2.3. After removing the module from the din rail, press in the tabs as noted above to remove the PCB from the housing. The fuse location is shown in the PCB view above. Use a multimeter to check for continuity across the fuse. If the fuse is blown, contact Magnetek to send the module in for service.
3. The total system Current Consumption should not exceed the Maximum Output Supply Current of 1000mA. If additional supply current is required, contact the factory for a custom solution.

## 5.0 FLEX SYSTEMS – OVERVIEW, SETTINGS AND WIRING DIAGRAMS

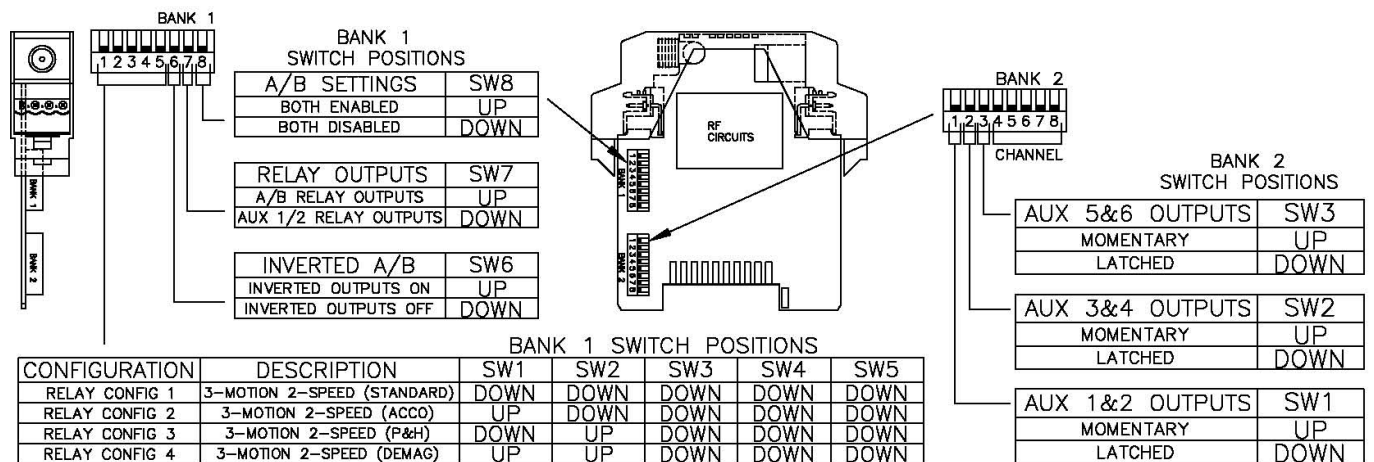
Magnetek offers the Pre-Engineered Flex M systems with the options for 16, 24, and 32 relay outputs. The following sections describe the overview and wiring diagrams for the Pre-Engineered Flex M systems.

### 5.1 FLEX M-16 SYSTEM OVERVIEW

FlexM-16 16 output Flex M system with 120VAC power card, RF/CPU card, and two 8 output relay cards.

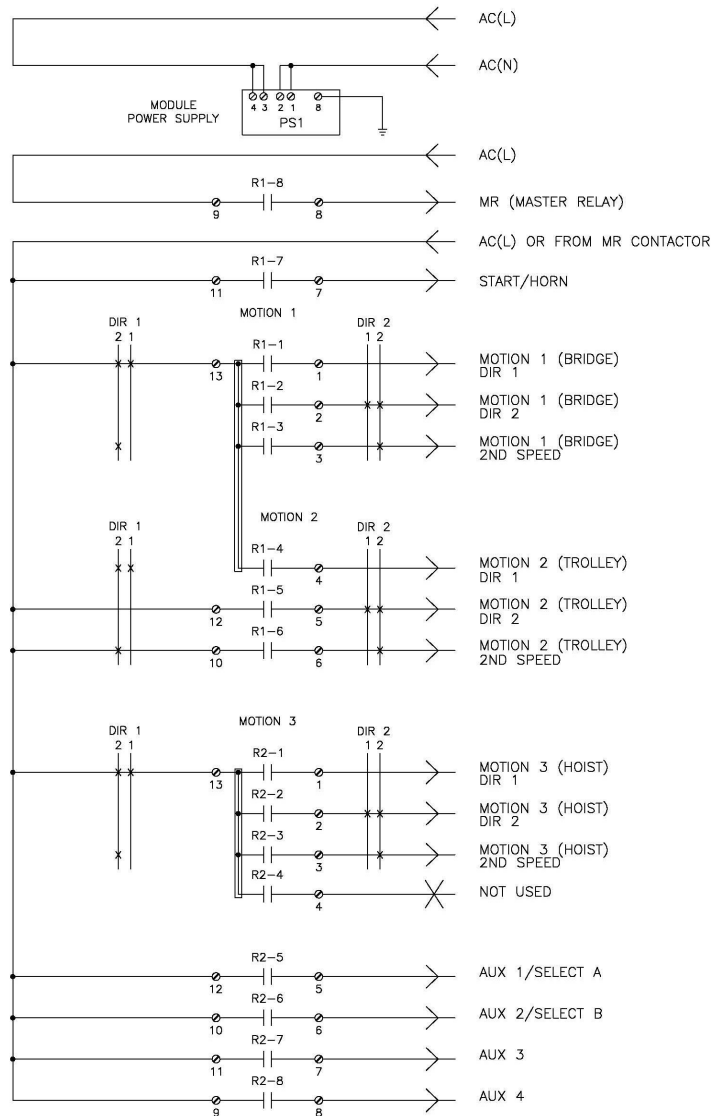
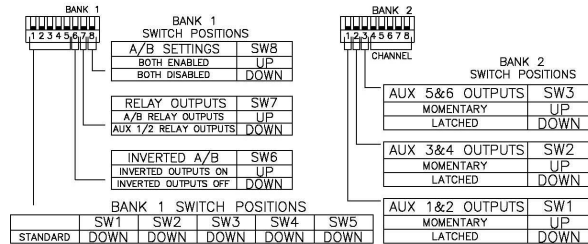


#### 5.1.1 Flex M 16 Relay Configuration Settings (Bank 1 on RF/CPU Module)

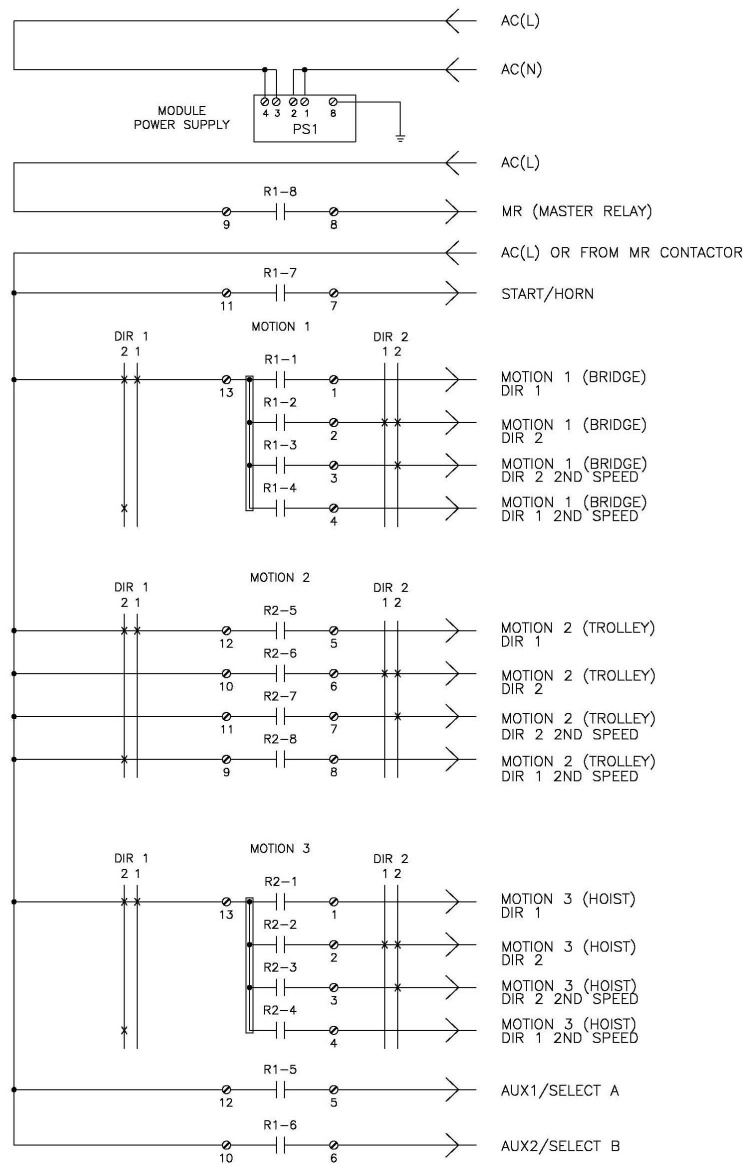
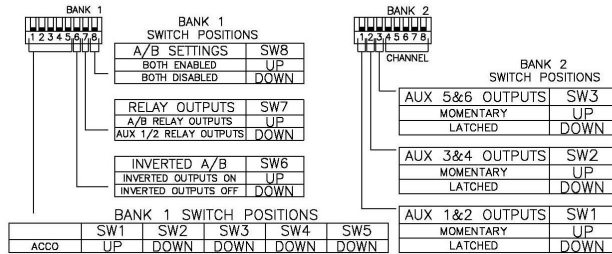


## 5.1.2 Flex M 16 Relay Configuration Descriptions

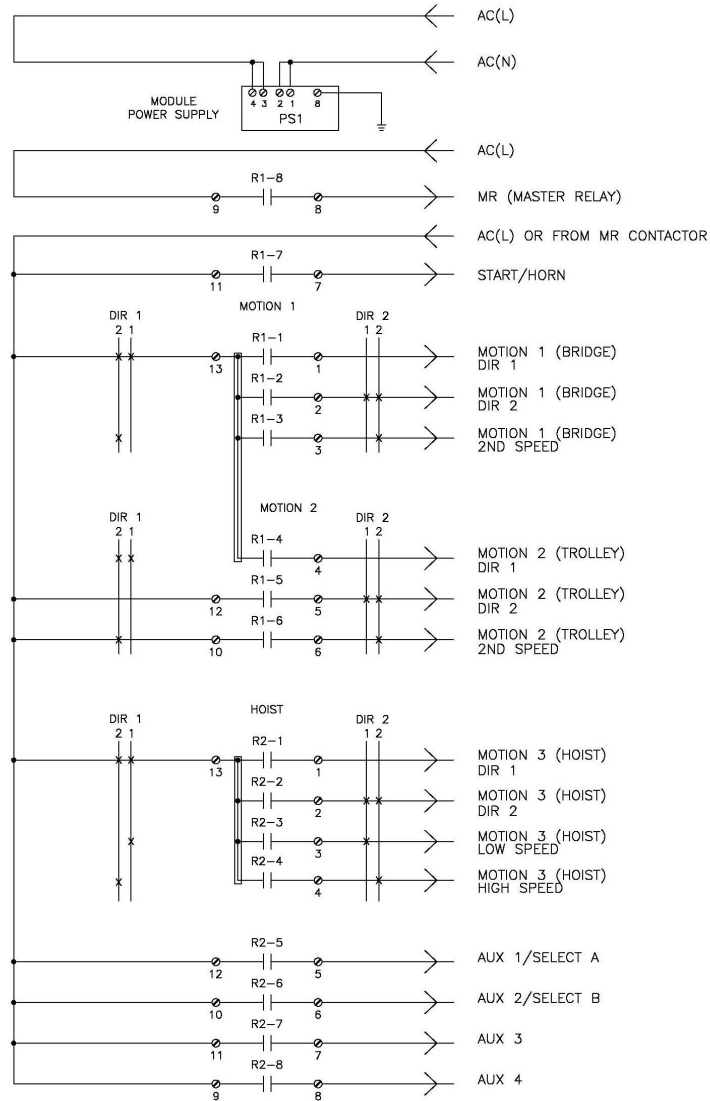
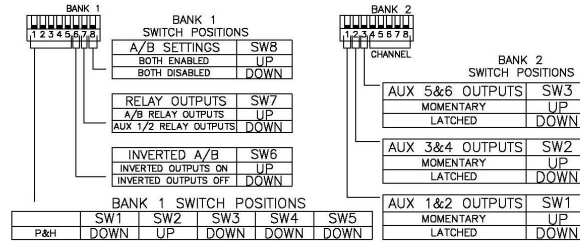
# RELAY CONFIGURATION 1 (STANDARD CONFIGURATION)



# RELAY CONFIGURATION 2 (ACCO CONTROLS)

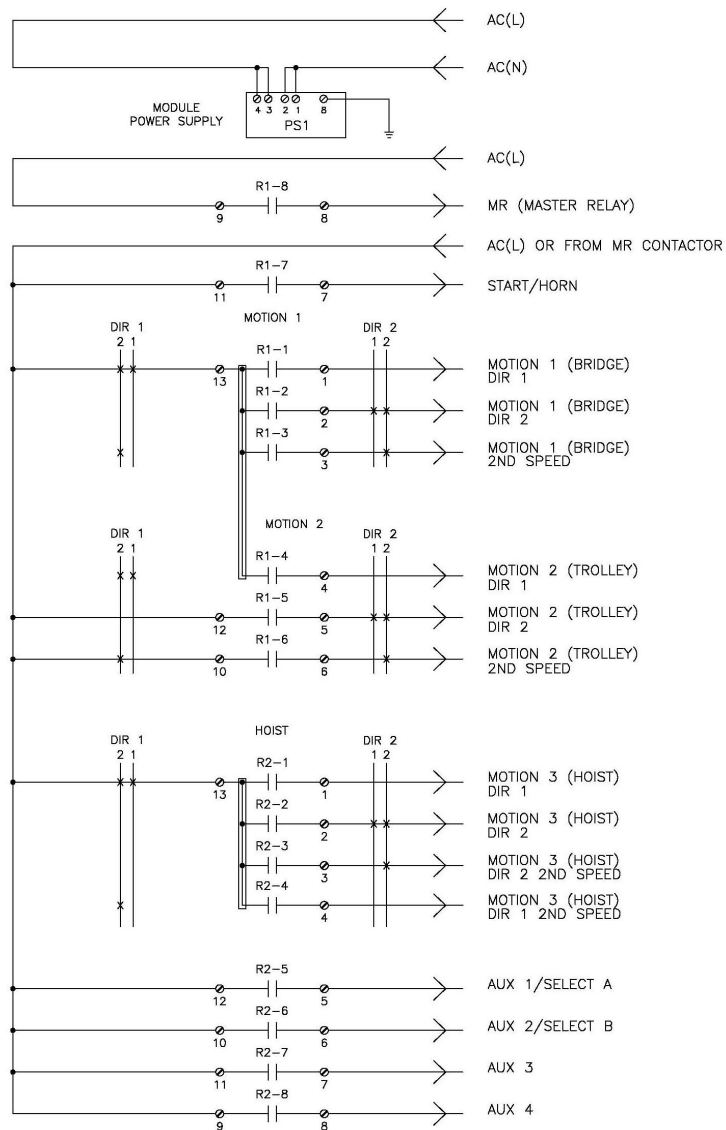
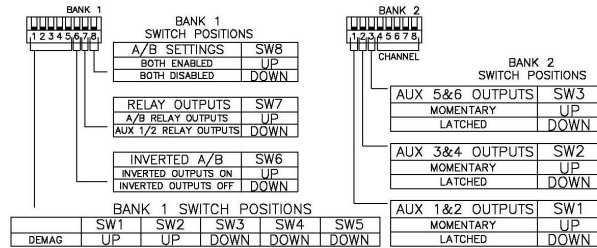


# RELAY CONFIGURATION 3 (P&H 2-SPEED, 2-WINDINGS: HOIST STANDARD TROLLEY & BRIDGE)



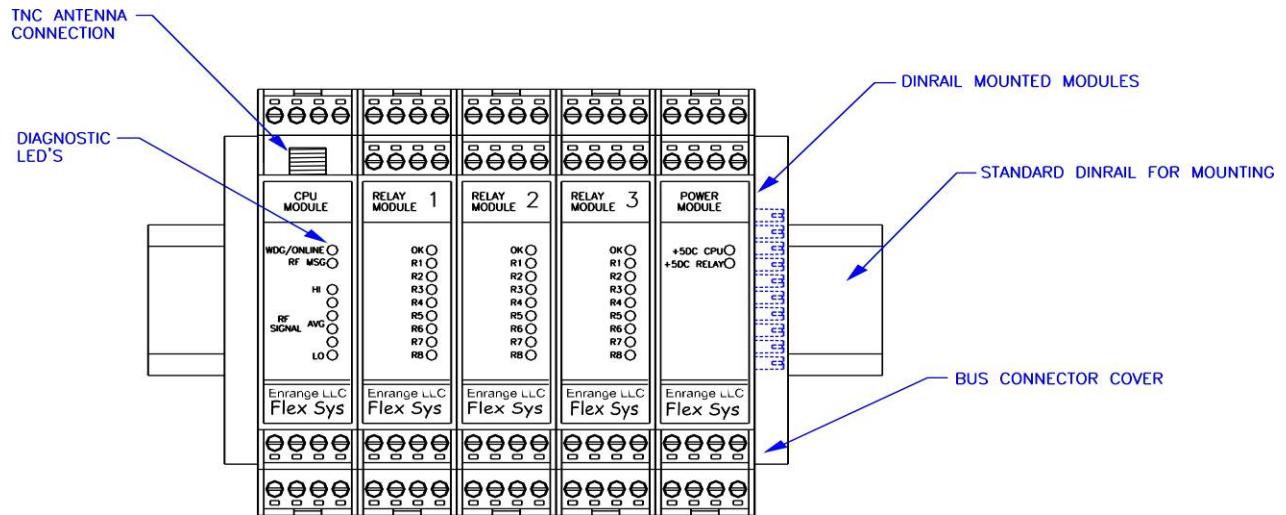
# RELAY CONFIGURATION 4

## (DEMAG 2-SPEED, 2-WINDINGS: HOIST STANDARD TROLLEY AND BRIDGE)

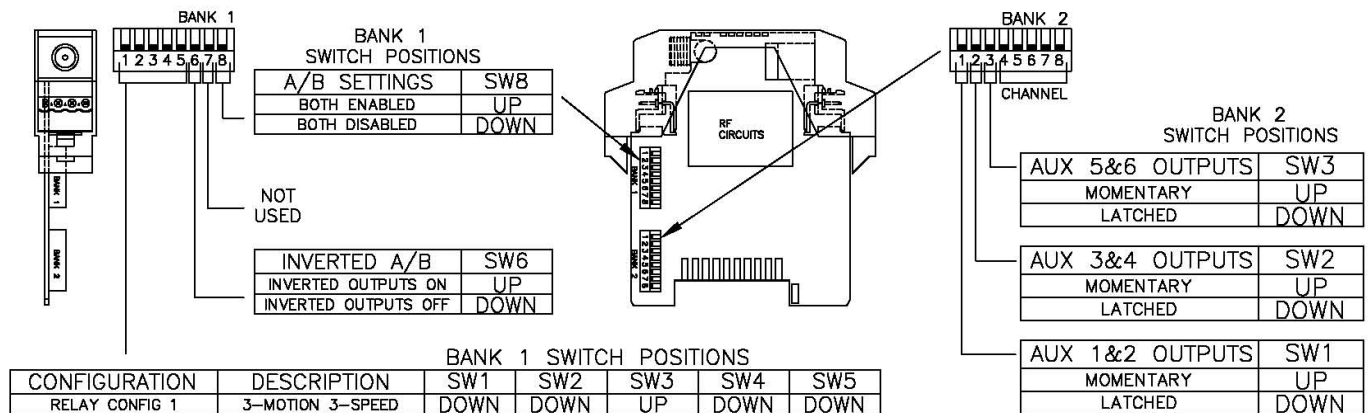


## 5.2 FLEX M-24 SYSTEM OVERVIEW

FlexM-24 24 output Flex M system with 120VAC power card, RF/CPU card, and three 8 output relay cards.



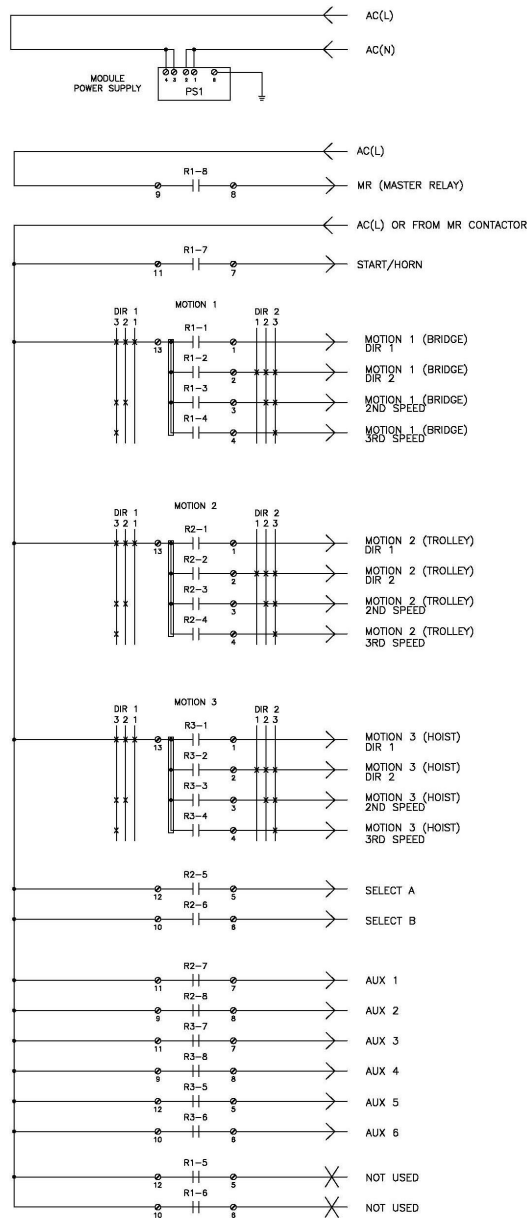
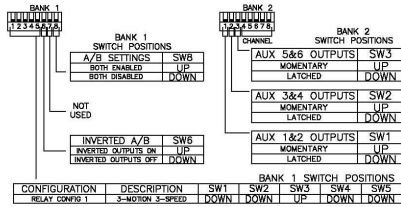
### 5.2.1 Flex M 24 Relay Configuration Settings (Bank 1 on RF/CPU Module)





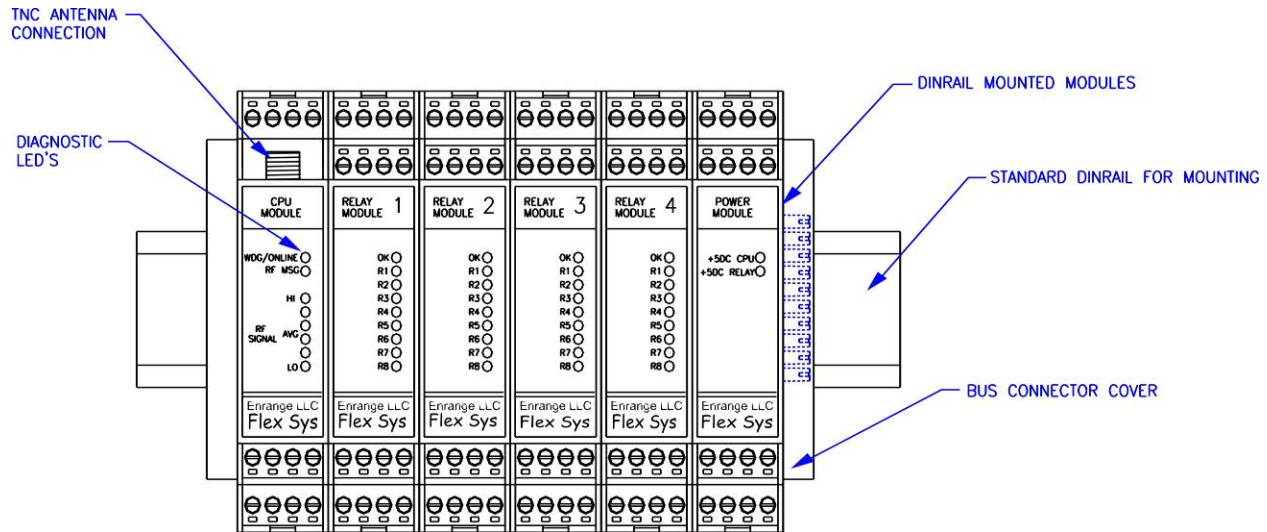
## 5.2.2 Flex M 24 Relay Configuration Descriptions

### RELAY CONFIGURATION 1 3-MOTION 3-SPEED

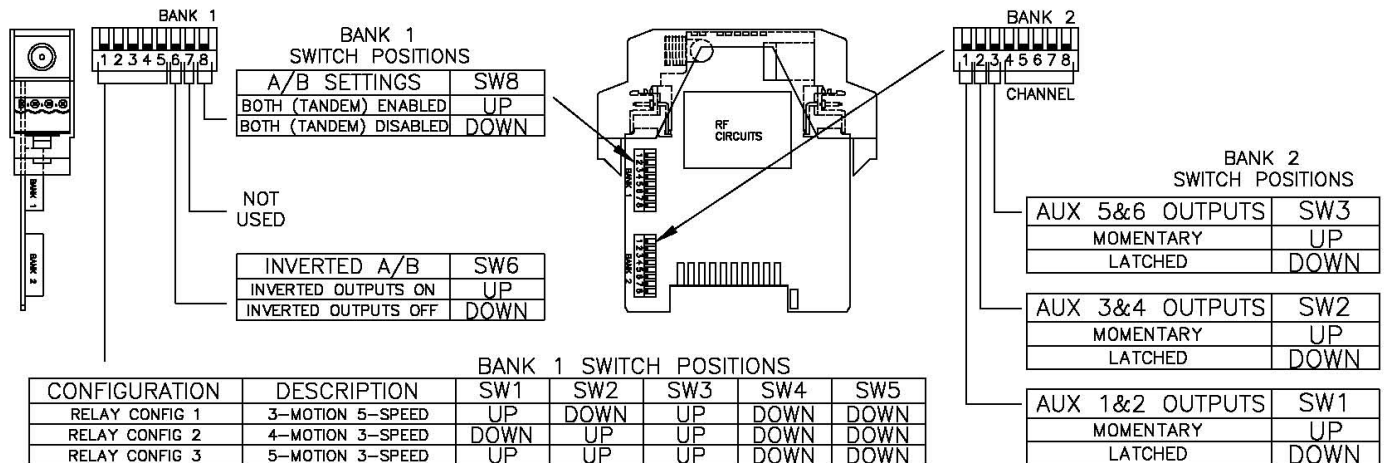


### 5.3 FLEX M-32 SYSTEM OVERVIEW

FlexM-32 32 output Flex M system with 120VAC power card, RF/CPU card, and four 8 output relay cards.

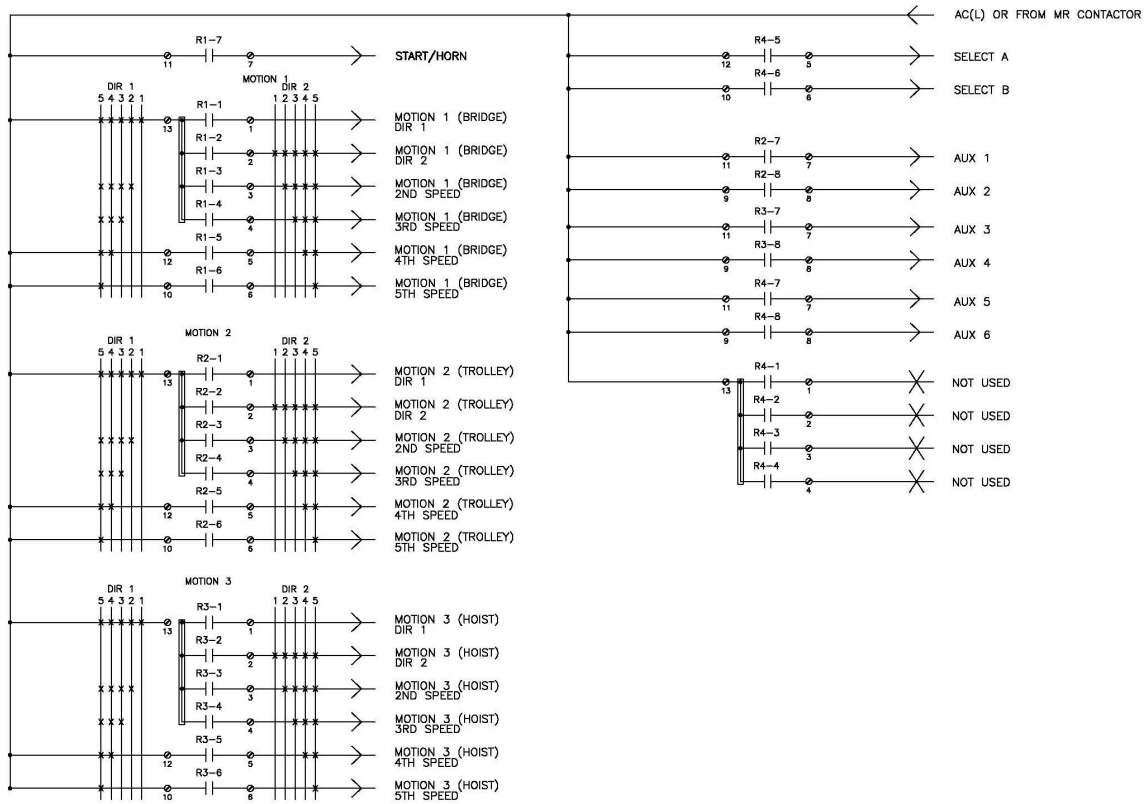
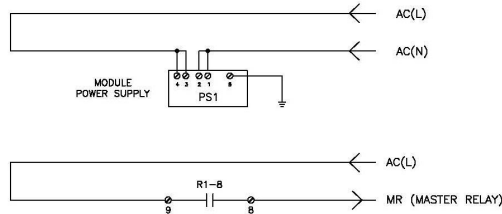
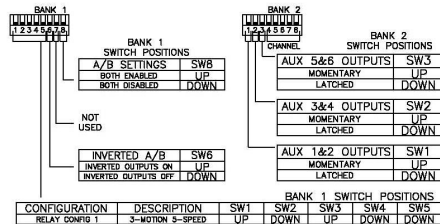


#### 5.3.1 Flex M 32 Relay Configuration Settings (Bank 1 on RF/CPU Module)



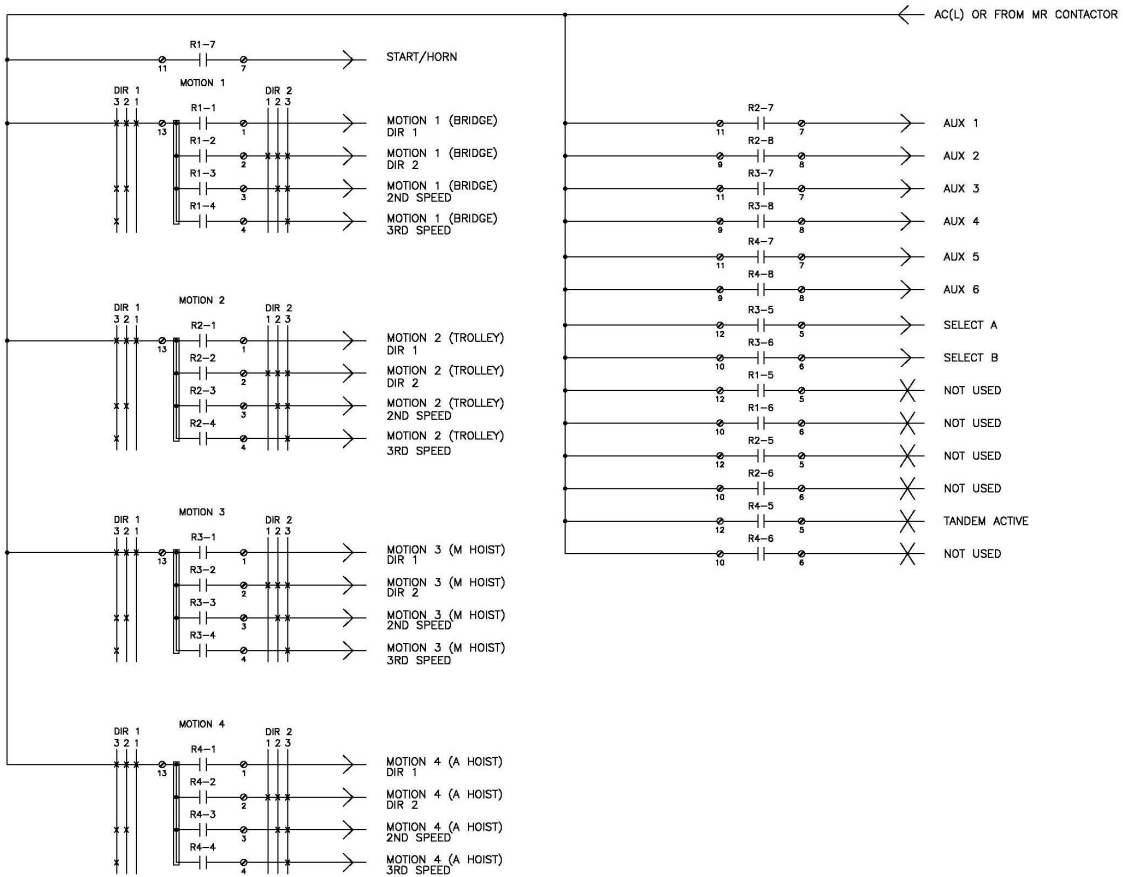
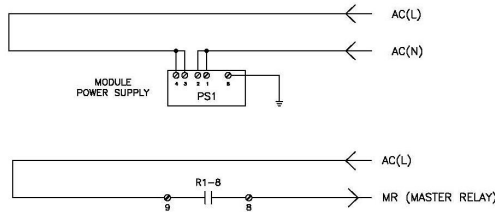
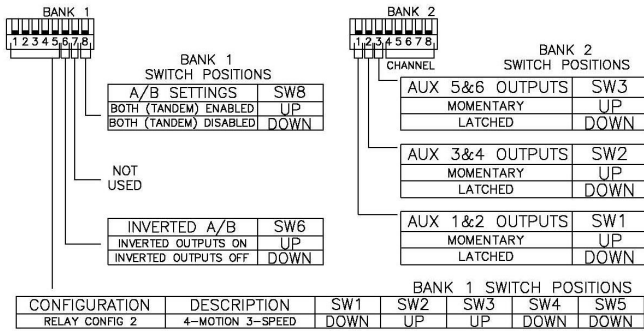
### 5.3.2 Flex M 32 Relay Configuration Descriptions

## RELAY CONFIGURATION 1 3-MOTION 5-SPEED



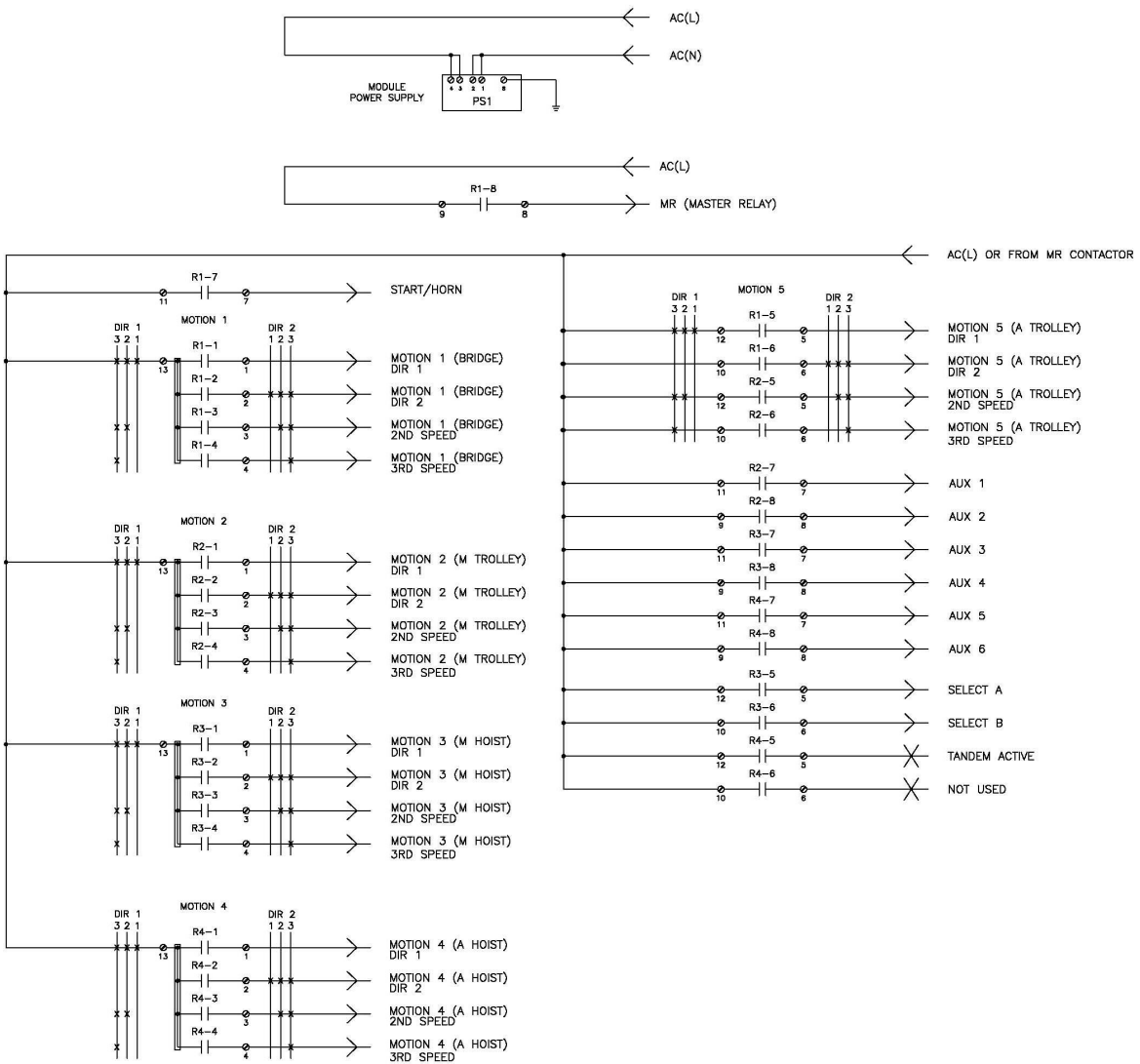
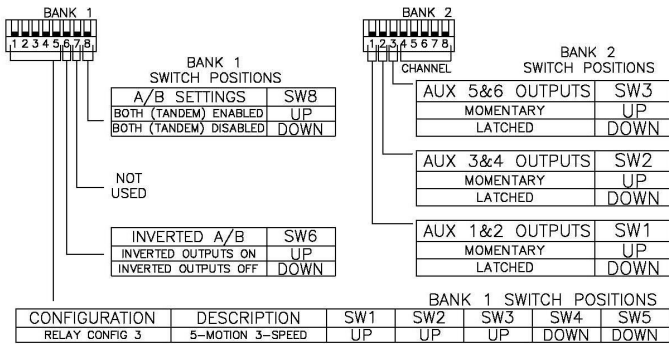
# RELAY CONFIGURATION 2

## 4-MOTION 3-SPEED

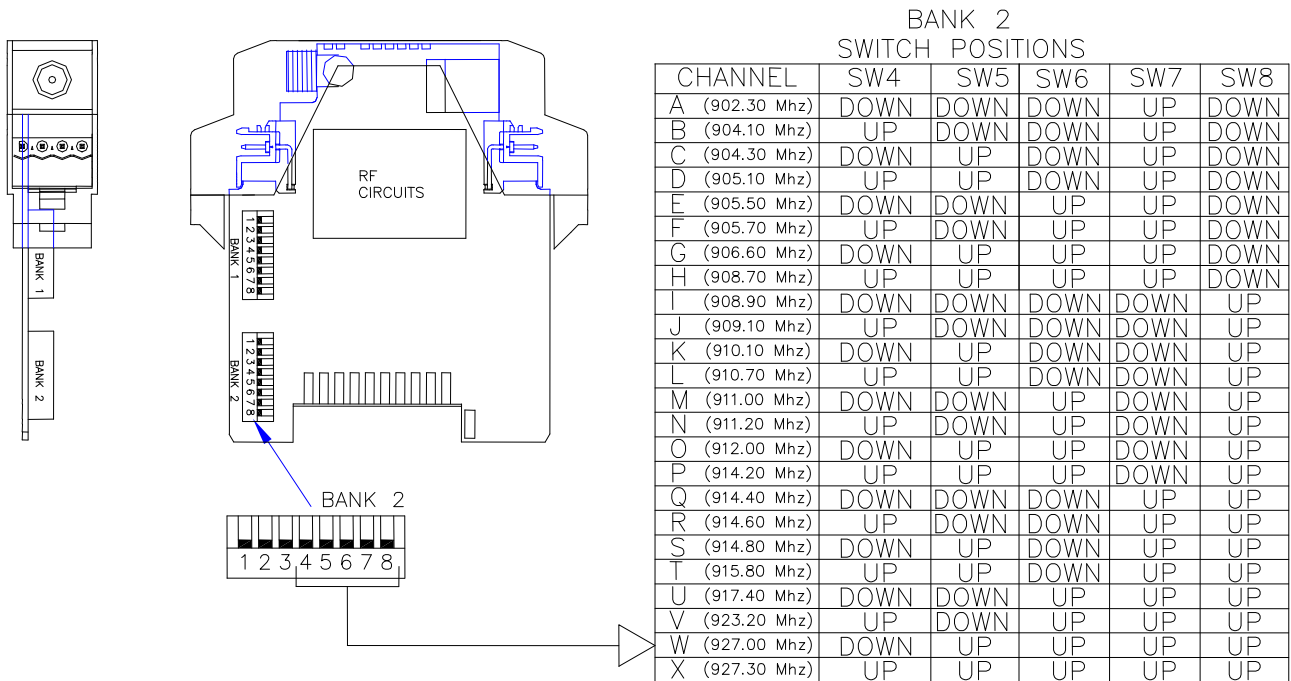


# RELAY CONFIGURATION 3

## 5-MOTION 3-SPEED



## 6.0 CHANNEL CONFIGURATION SETTINGS (BANK 2 ON RF/CPU MODULE)



NOTE: See Section 2.4 for instructions on how to remove the CPU/RF module from the Din rail and how to remove the PCB from the module housing.

## 6.1 FCC STATEMENTS

### Compliance Statement (Part 15.19)

This device complies with Part 15 of FCC rules.

Operation is subject to the following two conditions:

1. This device may not cause harmful interference, and
2. This device must accept any interference received, including interference that may cause undesired operation.

### Warning (Part 15.21)

Changes or modifications not expressly approved by the party responsible for compliance should void the user's authority to operate the equipment.

This portable transmitter with its antenna complies with FCC's RF exposure limits for general population/uncontrolled exposure.

## 7.0 TROUBLESHOOTING



### **WARNING**

THE OPERATOR SHOULD NOT ATTEMPT TO REPAIR ANY RADIO CONTROLLER. IF ANY PRODUCT PERFORMANCE OR SAFETY CONCERNS ARE OBSERVED, THE EQUIPMENT SHOULD IMMEDIATELY BE TAKEN OUT OF SERVICE AND BE REPORTED TO THE SUPERVISOR. DAMAGED AND INOPERABLE RADIO CONTROLLER EQUIPMENT SHOULD BE RETURNED TO MAGNETEK FOR EVALUATION AND REPAIR. FAILURE TO FOLLOW THIS WARNING COULD RESULT IN SERIOUS INJURY OR DEATH AND DAMAGE TO EQUIPMENT.

## 7.1 TROUBLESHOOTING TABLE

Problems	Possible Reasons	Suggestions
<b>Receiver will not turn on, +5VDC CPU/RELAY LEDs on Power Supply Module do not light up</b>	Supplied voltage is out of the acceptable range	Ensure the voltage is 120VAC nominal
	Internal fuse has blown on power supply module	Contact the factory for repair
	Internal power supply on PCB has a problem	Contact the factory for repair
<b>Receiver will not respond to the transmitter</b>	WDG/Online LED on CPU/RF module is blinking 2 times (communication loss with transmitter), and RF MSG LED does not blink.	Make sure the receiver and transmitter unit are both within range. Also verify that the transmitter is still on.
	WDG/Online LED on CPU/RF module is blinking 1 time (normal operating WDG), RF MSG LED does not blink and RF Signal Strength LEDs are indicating a signal strength.	Make sure the receiver and transmitter unit have the same access code.
	WDG/Online LED on CPU/RF module is blinking 1 time (normal operating WDG), RF MSG LED does not blink and RF Signal Strength LEDs are indicating an erratic signal.	Make sure the receiver and transmitter are both set to the same channel.
	WDG/Online LED on CPU/RF module is blinking 3 times, read/write error with relay modules	Make sure that the modules are securely put together; if the problem persists, contact factory for repair.
	The antenna on the receiver is missing, damaged, or improperly installed.	Inspect the antenna on the receiver for damage and try to locate the antenna in a location that is visible when operating the equipment at all times.



<b>Problems</b>	<b>Possible Reasons</b>	<b>Suggestions</b>
<b>Receiver responds to the transmitter inconsistently</b>	The transmitter is going in and out of range (transmitter and receiver are on the edge of the transmission range)	Move the transmitter and receiver closer together
		Relocate the receiver antenna to where it has a better line of sight with the transmitter
	The antenna and/or cable on the receiver is damaged, or improperly installed.	Inspect the antenna on the receiver for damage and try to locate the antenna in a location that is visible when operating the equipment at all times.
<b>The MLC (Master) Relay turns off during normal operation</b>	The transmitter powered down due to inactivity.	Extend the inactivity timeout setting for the transmitter.
	The transmitter powered down due to low batteries	Replace the transmitter's batteries.
	The RF/Message LED stops blinking for more than 3 seconds, followed by the MLC Relay turning off.	Radio interference - change the system's channel setting.
	The RF/Message LED stopped and the MLC Relay turned off together within 1 sec, possibly when engaging or disengaging another relay that is driving a contactor.	CPU module is resetting. Install snubbers across the coils of all contactors to reduce transient voltages. Ensure that the power module has a stable power source.

## 7.2 ASSEMBLY AND REPLACEMENT PARTS

<b>Description</b>	<b>Part Number</b>
900MHz CPU/RF Power Module	25-02-074-800E
120VAC Power Module	25-02-074-804E
Relay Module	25-02-074-805E
900MHz Antenna Kit	20-650-0021E
Module Replacement Plugs	01-300-0031E
Arc Suppressor/Snubbers	20-680-0000E